

PART NO.	NO. OF PINS
W17292-2PG-300	2
W17292-3PG-300	3

NOTES:

- PANEL CONNECTORS TO BE PACKED IN PARTITION BOX, 200 PC PER BOX
HEX NUT AND GASKET TO BE BULKPACKED IN A SEPARATE BAG FROM PANEL ASSEMBLY PACKAGE.
a) INNER BOX LABEL WITH CXA PART NUMBER, QUANTITY, LOT # AND DATE CODE ON LABEL AS SHOWN AND PLACED ON THE TOP BOX
- CONTACTS ARE INSERTED INTO PANEL CONNECTOR.
- ALL DIMENSIONS ARE FOR REFERENCE ONLY UNLESS OTHERWISE SPECIFIED.
- SEE DRAWING HPMCSTD FOR HOLE PATTERN

P/N: W17292-XPG-300
CONXALL
QTY.:
Lot:
Date Code:

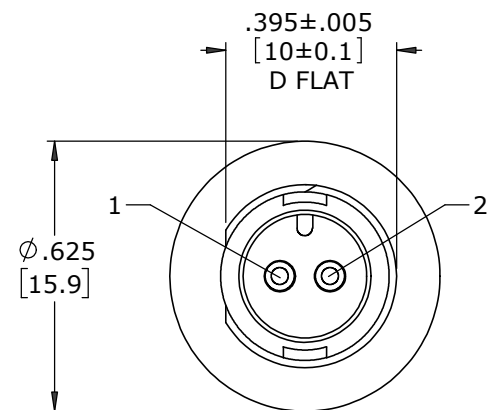

FACE VIEW
W17292-2PG-300

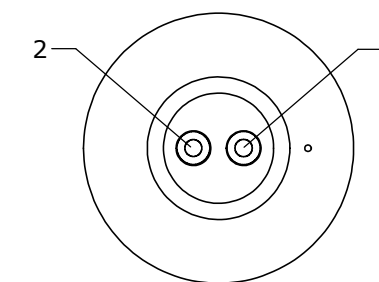
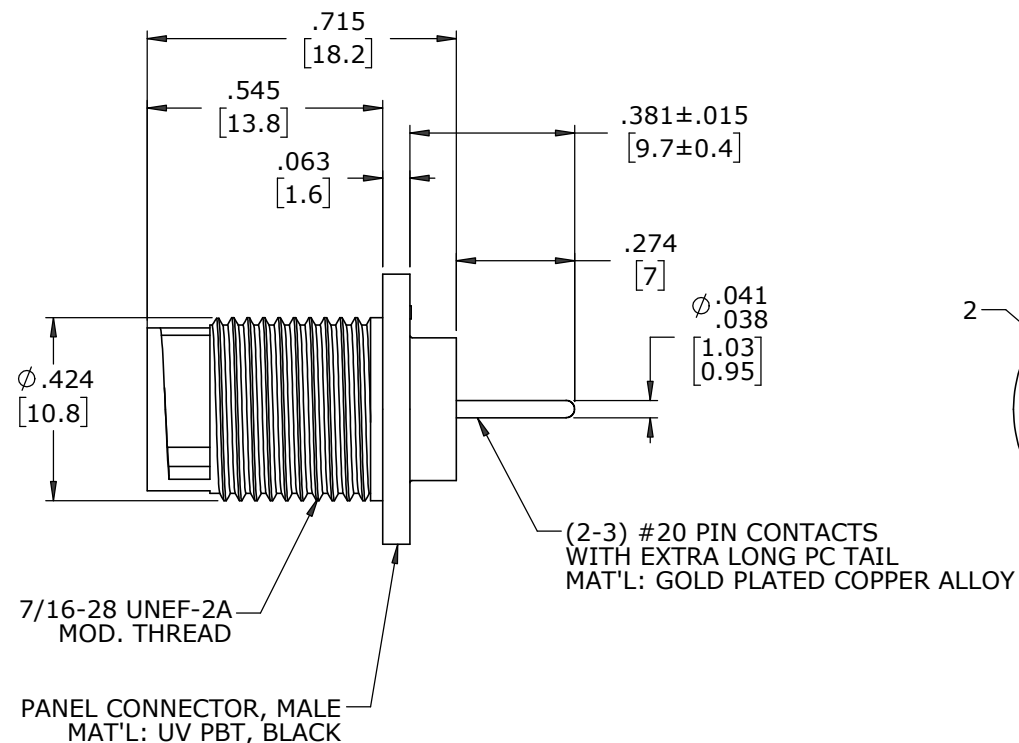
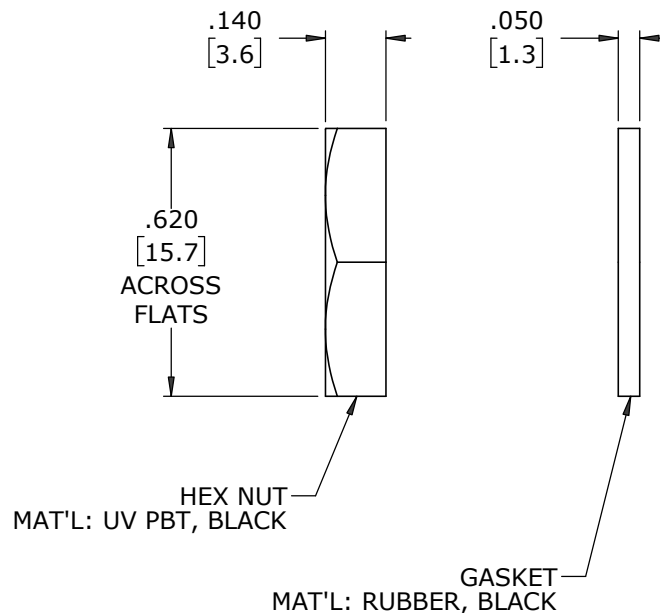

WIRE VIEW
W17292-2PG-300

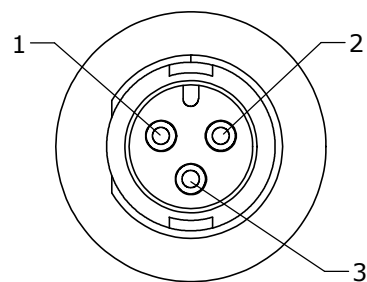

FACE VIEW
W17292-3PG-300

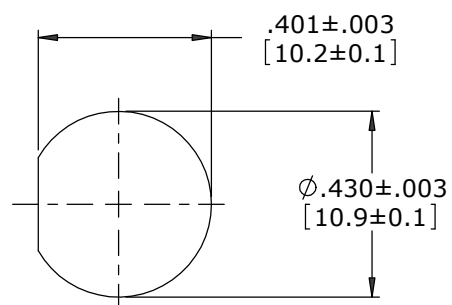

**RECOMMENDED
PANEL CUT-OUT**

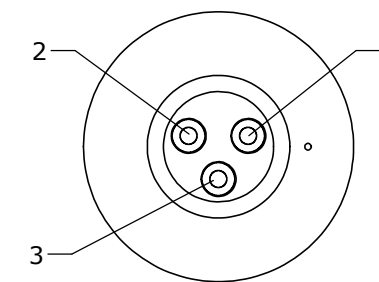

WIRE VIEW
W17292-3PG-300

CUSTOMER APPROVAL

THIS DOCUMENT CONTAINS CONFIDENTIAL INFORMATION PROPRIETARY TO CONXALL CORPORATION. ANY REPRODUCTION, DISCLOSURE, OR USE OF THIS DOCUMENT /INFORMATION IS EXPRESSLY PROHIBITED UNLESS AUTHORIZED IN WRITING BY CONXALL CORPORATION.

APPROVED BY: _____
DATE: _____

RoHS COMPLIANT

A	MA	10-04-23	DRAWING CREATED PER DOR 16-E256SL-59
REV.	INIT.	DATE	DESCRIPTION
	MA	10-04-23	ORIG. DRAWN BY: DATE: CHECKED BY:
ALL INFORMATION ILLUSTRATED IS THE PROPERTY OF "CONXALL CORPORATION". UNAUTHORIZED DUPLICATION OR DISTRIBUTION OF THIS DOCUMENT IS PROHIBITED.			 601 E. WILDWOOD VILLA PARK, IL 60181
ALL UNITS ARE IN FEET, INCHES, FRACTION OF INCHES AND DECIMALS.			
APPROVED BY:		TITLE: PANEL MOUNT ASSEMBLY (2-3) #20 PIN CONTACTS, XL PC TAIL MICRO-CON-X	
SCALE	SIZE	SHEET	CUSTOMER: STANDARD PRODUCT
NTS	B	1 OF 1	
FILE:	DIRECTORY:	PART NUMBER:	REV
W17292-XPG-300	SLW	W17292-XPG-300	A

CUSTOMER PRINT

PART NUMBER: W17292-XPG-300