

SPECIFICATIONS:	
MECHANICAL	
Mating / Locking Type:	Push-Pull automatic locking/unlocking
Life	5,000 cycles minimum
Operating Forces	10 lb. [44.5 N] maximum Insertion or Withdrawal
Vibration	Mil-Std 202G Method 201A
Panel-Mount Hex Nut Tongue	40 in-lb [4.5 Nm] maximum
Cable Securing System:	Threaded on metal Clamp
ELECTRICAL	
Voltage Rating	125 V AC/DC for 2-5 contact arrangements 30 V AC/DC for 6-9 contact arrangements
Current Rating	Refer to Current Carry Capacity Table
Insulation Resistance	1000 MΩ minimum
Contact Resistance	10 mΩ typical
EMI Shielding	360°
ENVIRONMENTAL	
Temperature Limits	-40°C to +135°C (-40°F to +275°F)
Operating Temperature Range	Refer to Current Carry Capacity Table
Moisture Resistance	Mil-Std 202G Method 106G
Insulation Resistance	Mil-Std 202G Method 302
Thermal Shock	Mil-Std 202G Method 107G
Salt Atmosphere (Corrosion)	Mil-Std 202G Method 101E
Ingress Protection Ratings	IP66, IP67, IP68 (6 ft. for 24 hours) per IEC60529, NEMA 250 6P
MATERIAL	
Outer Shell Metal components	Copper Alloy, electroless nickel plated
Hex Nut & Inner Metal components	Copper Alloy, nickel plated
Ground Spring Washer	Stainless Steel
Electrical Insulator	Medical Technology LCP, natural
Seal O-rings	Silicone, red
Contacts	Copper Alloy, gold plated with Stainless Steel locking clip
Connector Potting	Silicone Potting Compound

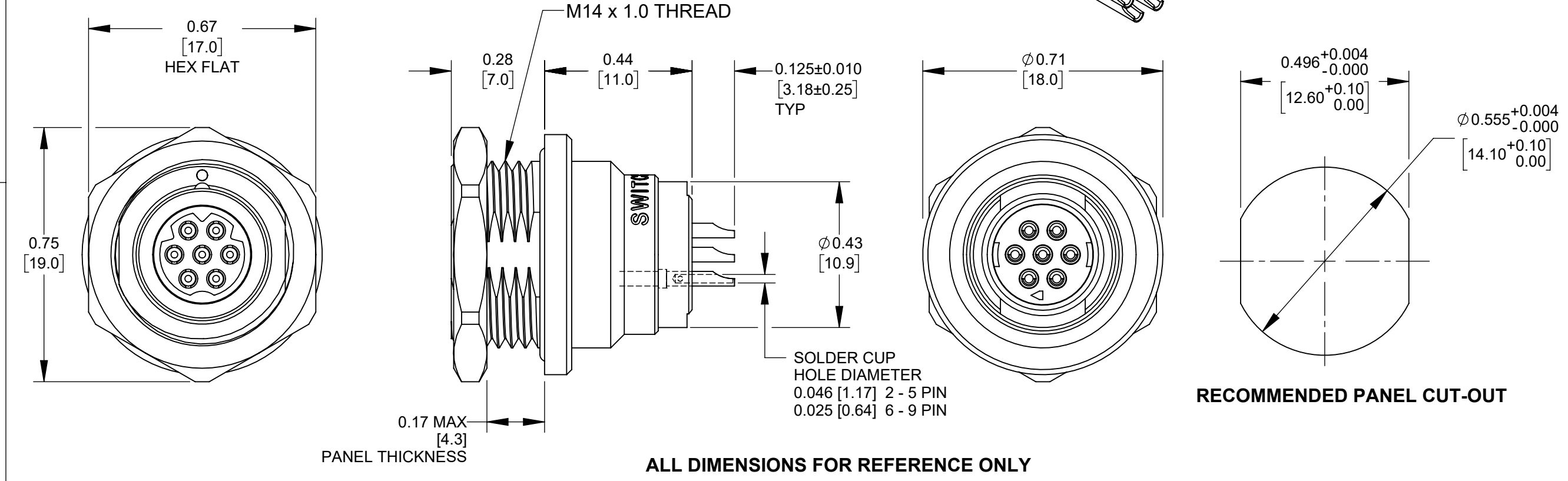
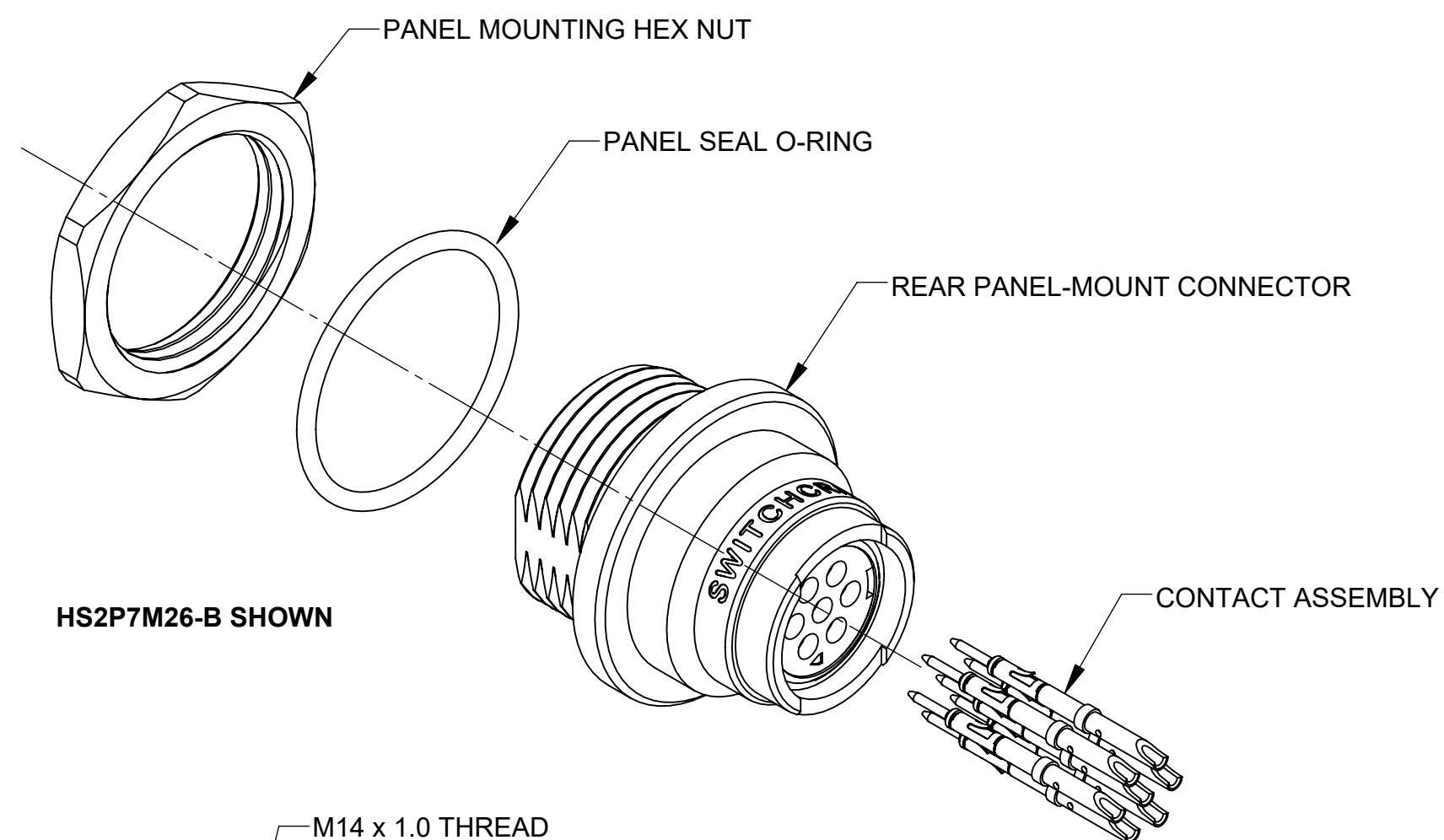

Contacts	Wire (awg)	Current Rating (A) at Operating Temperature (°C)					Minimum Test Voltage (V rms)	Voltage (V rms) tested per UL2238
		45°C max.	65°C max.	85°C max.	100°C max.	110°C max.		
2 #20	20	10	9	8	7*	6	1400	125
	22	8.5	7.5	7.5	5.5*	4.5		
	24	7	6	5	4.5*	3.5		
	26	4	4	3.5	3.5*	2.5		
3 #20	20	9.5	8.5	7.5	6.5*	5		
	22	8	7	6	5*	4		
	24	6	5.5	4.5	4*	3		
	26	3.5	3.5	3	3*	2.5		
4 #20	20	9	8	7	6*	5		
	22	7.5	6.5	5.5	4.5*	3.5		
	24	5	4.5	4	3.5*	2.5		
	26	3	3	2.5	2.5*	2		
5 #20	20	8	7.5	6.5	5.5*	4.5		
	22	6.5	5.5	5	4*	3		
	24	4.5	4	3.5	3*	2.5		
	26	2.5	2.5	2	2*	1.5		
6-7 #26	26	2.5	2.5	2	2*	1.5		
	28	2	2	1.5	1.5*	1		
	30	1.5	1.5	1	1*	.5		
	26	2	2	1.5	1.5*	1		
8-9 #26	28	1.5	1.5	1	1*	.5		
	30	1	1	.5	.5*	.5		
	26	2	2	1.5	1.5*	1		
	28	1.5	1.5	1	1*	.5		

*Temperature Rise does not exceed 30°C when tested according to UL2238. All other recommended current ratings are based on the Relative Thermal Index of the insulating material.

TOOL	TOOL TYPE	POSITIONER	CONTACT SIZE	WIRE SIZES
EN3CR	HAND CRIMP TOOL	EN2POS20	20 and 22	20 and 22 AWG
		EN3POS26	26	26, 28, and 30 AWG
EN3CRAUTO	PNEUMATIC CRIMP TOOL	EN2POS20	20 and 22	20 and 22 AWG
		EN3POS26	26	26, 28, and 30 AWG
EN2CRL	HAND CRIMP TOOL LARGE FRAME	EN2POS20L	20 and 22	20, 22, 24, and 26 AWG
EN2CRAUTOL	PNEUMATIC CRIMP TOOL LARGE FRAME			
INSTOOL20	CONTACT INSERTION	--	20	20, 22, 24, and 26 AWG
INSTOOL26	CONTACT INSERTION	--	26	26, 28, and 30 AWG
REMT00L20	CONTACT EXTRACTION	--	20	20, 22, 24, and 26 AWG
REMT00L26	CONTACT EXTRACTION	--	26	26, 28, and 30 AWG

REV	ECO NUMBER	DATE	BY	APVD
A	28369	03/16/21	PC	TJK

UNLESS OTHERWISE SPECIFIED

1. ALL DIMENSIONS IN INCHES [mm]

- TWO PLACE DECIMALS ±0.02 [0.5]

- THREE PLACE DECIMALS ±0.005 [0.13]

DO NOT SCALE DRAWING

THIS DRAWING DESCRIBES A DESIGN CONSIDERED PROPRIETARY IN NATURE, DEVELOPED AND MANUFACTURED BY SWITCHCRAFT INC. AND IS RELEASED ON A CONFIDENTIAL BASIS FOR IDENTIFICATION PURPOSES ONLY.

SIZE	WIDTH	MULT	LBS/M	TEMPER
FINISH	SCALE		MATERIAL	
SPEC No.	3:1		SPEC No.	
DATE DRAWN	BY	CHKD	APVD	
03/09/21	TS	03/09/21	3/12/21	
NAME PANEL CONNECTOR, REAR MOUNT, SOLDER CUP/CRIMP, RoHS			PART No.	REV
			HS2P_-B_SERIES	A

SHEET 1 OF 2

8 SolidWorks CAD File

CUSTOMER DRAWING

STEP 1

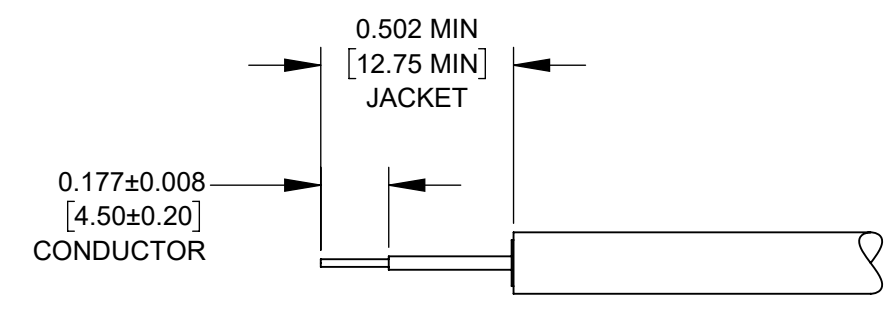

STRIP THE CABLE OR SINGLE CONDUCTORS AS SHOWN.

STEP 2

ONE CONTACT SHOWN HERE FOR CLARITY

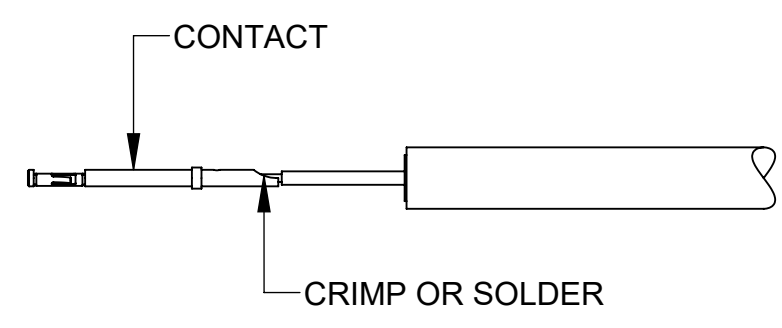

CRIMP CONDUCTORS TO CONTACTS USING HAND OR PNEUMATIC CRIMP TOOL* WITH CRIMP POSITIONER* SET PER CONTACT SIZE AND WIRE GAGE.
IF SOLDERING, IT IS RECOMMENDED TO SOLDER CONDUCTORS TO CONTACTS BEFORE INSTALLATION.

STEP 3

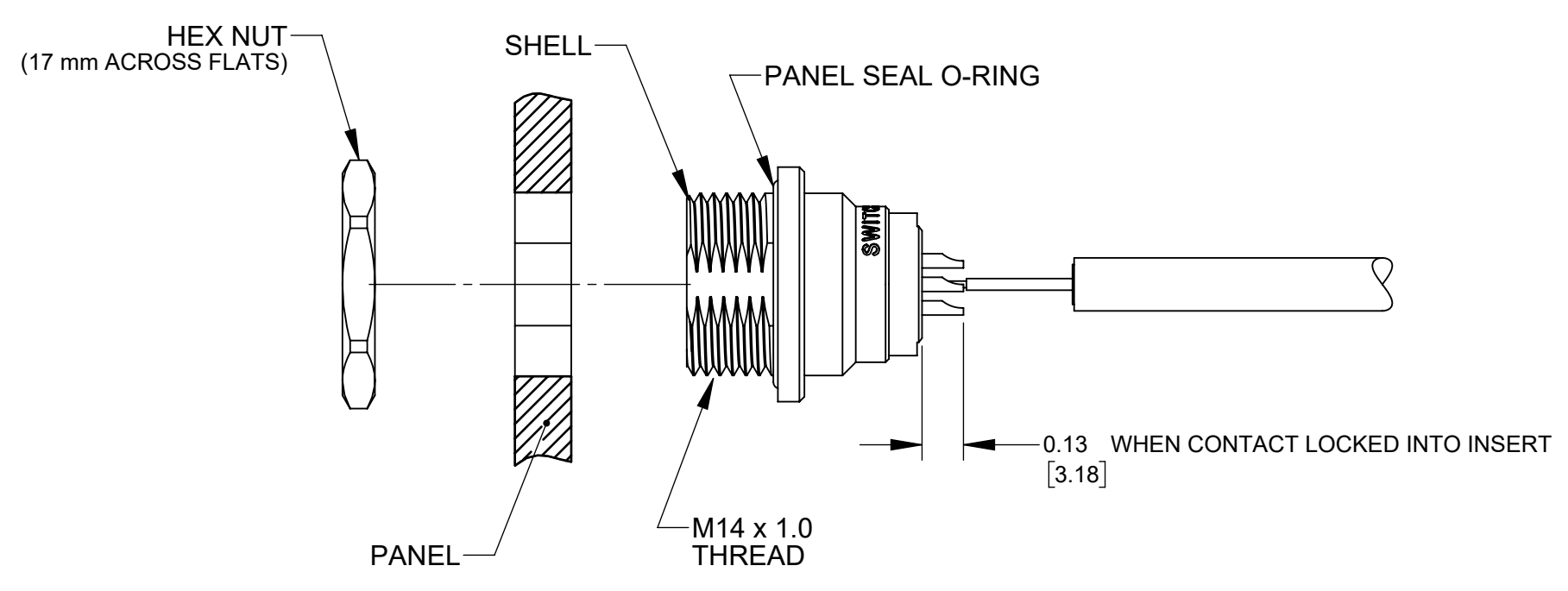

INSTALL PANEL SEAL O-RING ONTO SHELL AS SHOWN.
NOTE: CONVENIENTLY, CONTACTS CAN BE INSTALLED EITHER BEFORE OR AFTER SHELL INSTALLATION ON THE PANEL.
GUIDE EACH WIRED CONTACT INTO INSERT HOLE AND PUSH UNTIL CONTACT SNAPS IN PLACE. USE INSERTION TOOL* IF NECESSARY.
COLORED CONDUCTORS CAN BE ASSIGNED TO CONTACT POSITION NUMBERS AS DESIRED.
TO REMOVE A CONTACT, INSERT THE EXTRACTION TOOL* FROM THE FRONT OF INSERT AND LIGHTLY PRESS THE SPRING LOADED PLUNGER INWARD TO PUSH THE CONTACT OUT.

STEP 4

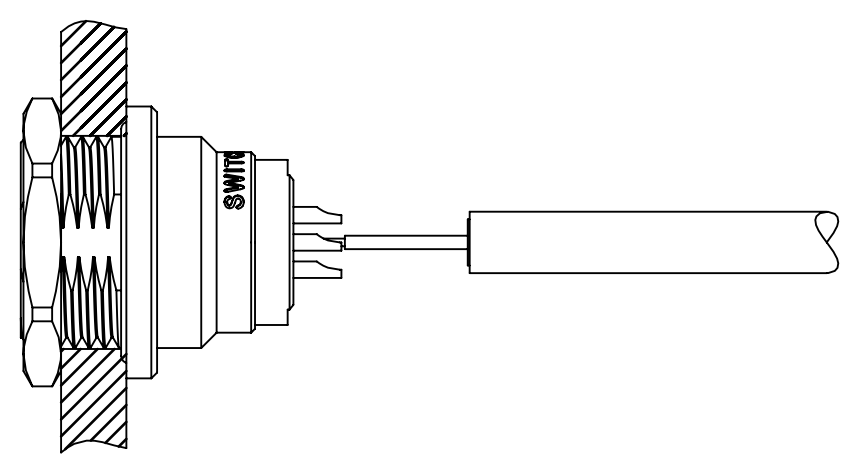

ALIGN AND INSTALL FINISHED CONNECTOR INTO PANEL CUT-OUT. TIGHTEN HEX NUT TO A MAXIMUM OF 40 IN-LB [4.5 Nm] TORQUE. A 17 mm WRENCH CAN BE USED.

*REFER TO TOOLS TABLE ON THIS DRAWING FOR SELECTION OF TOOLS PER CONTACT AND WIRE SIZE.

HS2 SERIES REAR PANEL-MOUNT FIELD ASSEMBLY INSTRUCTIONS

CUSTOMER DRAWING

SCALE 2:1	Switchcraft®	
DATE DRAWN 03/09/21		
DRAWN BY TS	PART No. HS2P_-B_SERIES	REV A