

**EP7C3F10
3-POLE FEMALE**

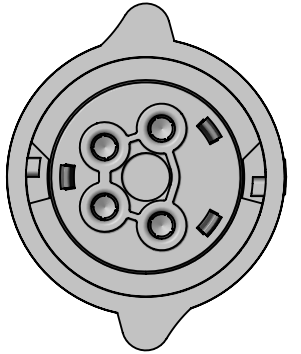

**EP7C4F10
4-POLE FEMALE**

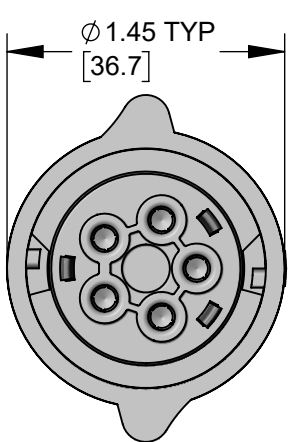

**EP7C5F10
5-POLE FEMALE**

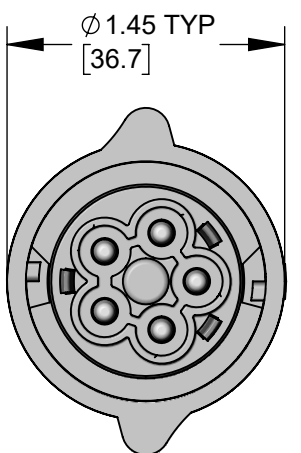

**EP7C5M10
5-POLE MALE**

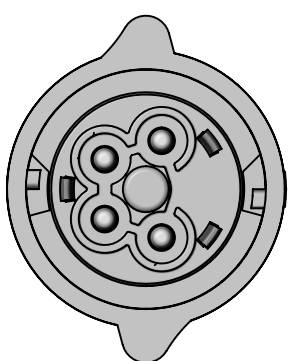

**EP7C4M10
4-POLE MALE**

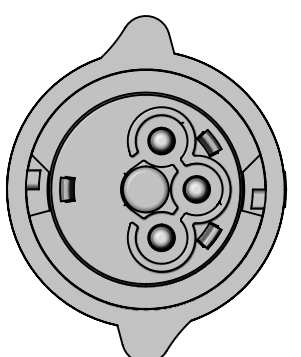

**EP7C3M10
3-POLE MALE**

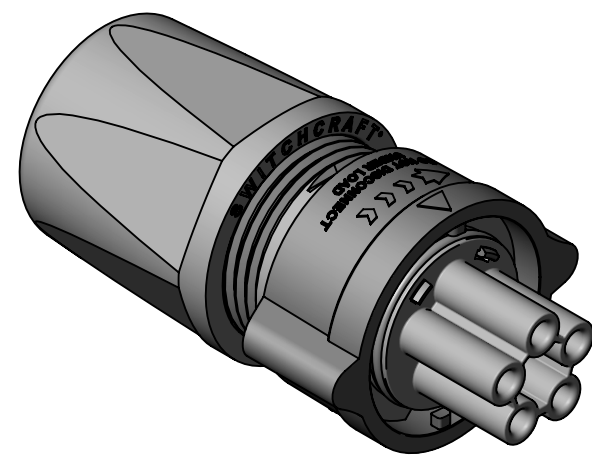

EP7C5F10C SHOWN

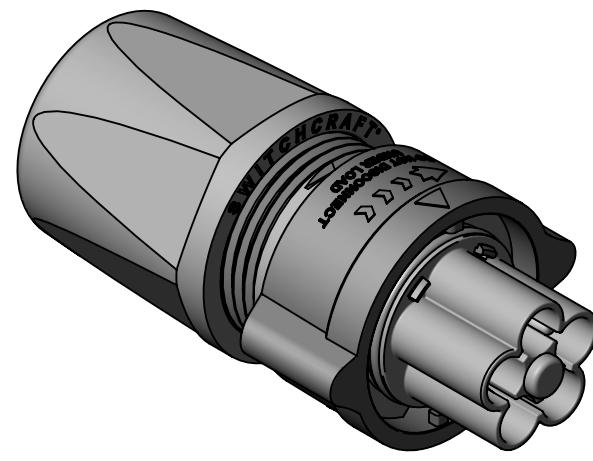

EP7C5M10C SHOWN

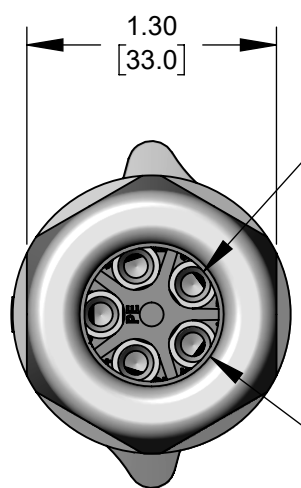
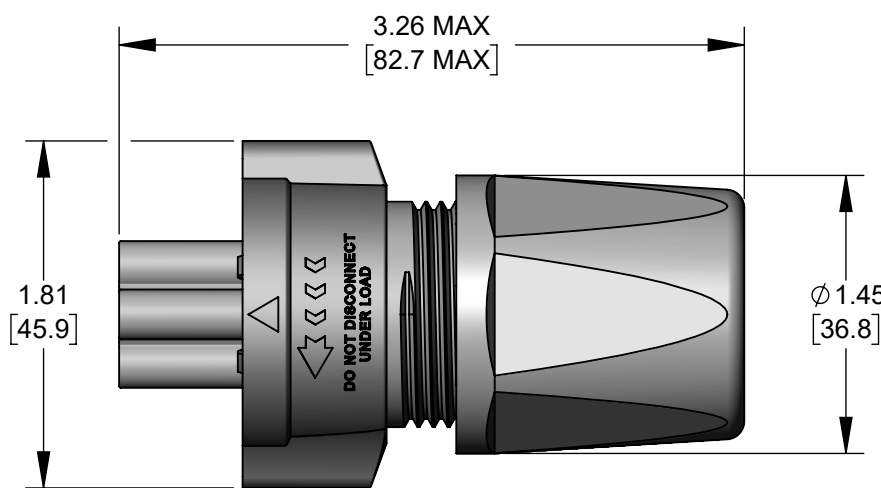

GROMMET I.D., TYPICAL:
SIZE A: 0.500 [12.7] DIA.
SIZE B: 0.600 [15.2] DIA.
SIZE C: 0.700 [17.8] DIA.

BACK NUT I.D., TYPICAL:
0.65 [16.5] - USED WITH GROMMET SIZE A
0.75 [19.0] - USED WITH GROMMET SIZE B OR C

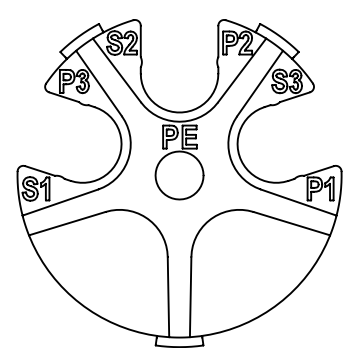
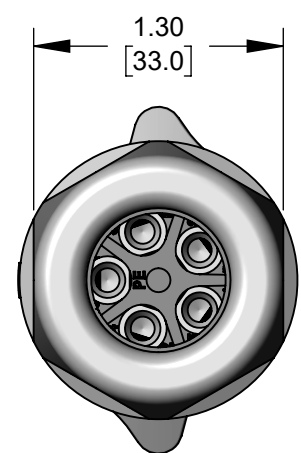
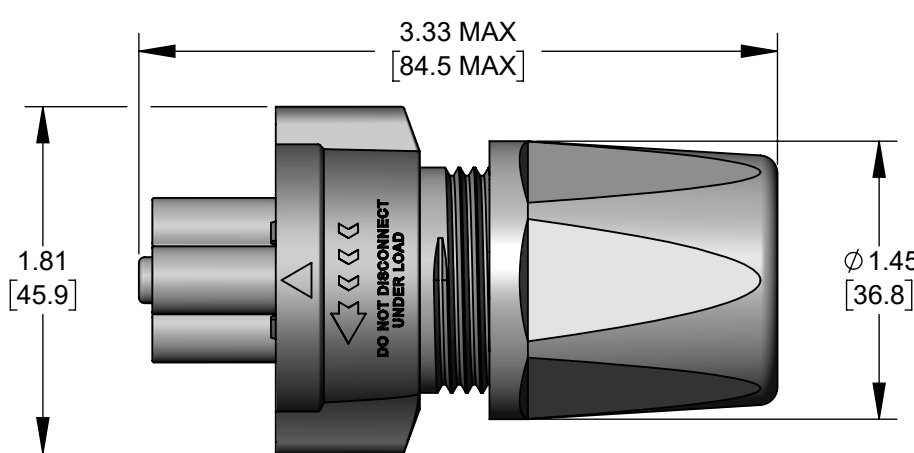

3-POLE

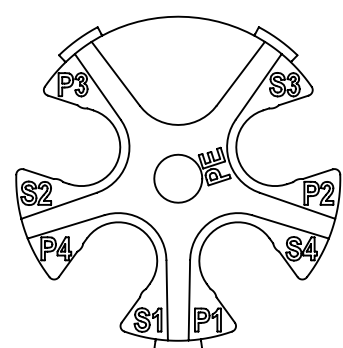

4-POLE

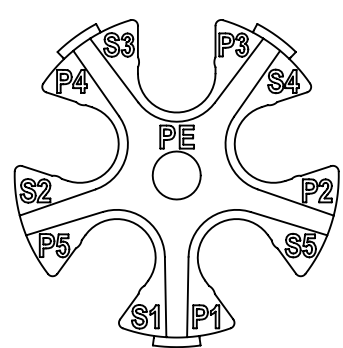

5-POLE

INSERTS (CONTACT CARRIERS) REAR VIEW SHOWN FOR CLARITY
S1-S5: SOCKET CONTACT POSITIONS, COUNTED CLOCKWISE
P1-P5: PIN CONTACT POSITIONS, COUNTED COUNTERCLOCKWISE
PE: PROTECTIVE EARTH

EP7 C 10

EP7 SERIES
C - CABLE-END CONNECTOR

OF CONTACTS:
3-5 #10

GENDER:
M - MALE (PIN)
F - FEMALE (SOCKET)

KIT PACKAGING OPTION:
K - ONE UNIT / BAG

GROMMET SIZE - CABLE O.D. RANGE:
A - 0.375 - 0.500 [9.5 - 12.7]
B - 0.500 - 0.600 [12.7 - 15.2]
C - 0.600 - 0.700 [15.2 - 17.8]

CONTACT SIZE - (WIRE SIZES):
10 - (10, 12, 14 AWG)

REFER TO "EP7P SERIES" DRAWING FOR MATING PANEL-MOUNT CONNECTORS.
REFER TO "EP7L SERIES" DRAWING FOR MATING CABLE-TO-CABLE CONNECTORS.

SPECIFICATIONS:	
MECHANICAL	
Mating / Locking Type:	Spring Loaded Automatic Latching Mechanism
Life	400 cycles minimum
Operating Forces	10 lb. [44.5 N] maximum Insertion or Withdrawal
Vibration	Mil-Std 202G Method 201A
Panel-Mount Hex Nut Torque	12 in-lb [1.36 Nm] maximum
Cable Securing System:	Treaded-on Clamp
ELECTRICAL	
Voltage Rating	600 V AC/DC
Current Rating	Refer to Current Carry Capacity Table
Insulation Resistance	1000 MΩ minimum
Contact Resistance	10 mΩ typical
ENVIRONMENTAL	
Temperature Limits	-40°C to +135°C (-40°F to +275°F)
Operating Temperature Range	Refer to Current Carry Capacity Table
Moisture Resistance	Mil-Std 202G Method 106G
Insulation Resistance	Mil-Std 202G Method 302 Condition B
Thermal Shock	Mil-Std 202G Method 107G
Salt Atmosphere (Corrosion)	Mil-Std 202G Method 101E Condition A
Ingress Protection Ratings	IP66, IP67, IP68 (6 ft. for 24 hours) per IEC60529, IP69K per DIN 40050-9, NEMA 250 6P
MATERIAL	
Outer Shell (Insulator), Hardware	Thermoplastic (PA)
Seal Grommets	Thermoplastic Elastomer (TPV)
Seal O-rings	Thermoplastic Elastomer (VMQ)
Electrical Contacts	Copper Alloy, Gold Plated
Spring, Terminal Screw	Stainless Steel

Contacts	Wire (awg)	Current Rating (A) at Operating Temperature (°C)					Minimum Test Voltage (V rms)	Voltage (V rms) tested per UL2238
		45°C max.	65°C max.	85°C max.	100°C max.	110°C max.		
3 #10	10	30	30	30	25*	20	2200	600
	12	25	25	25	20*	15		
	14	20	20	20	15*	10		
4 #10	10	30	30	30	25*	20		
	12	25	25	25	20*	15		
	14	20	20	20	15*	10		
5 #10	10	30	30	30	25*	20		
	12	25	25	25	20*	15		
	14	20	20	20	15*	10		

*Temperature Rise does not exceed 30°C when tested according to UL2238. All other recommended current ratings are based on the Relative Thermal Index of the insulating material.

NOTES:

1. ALL DIMENSIONS FOR REFERENCE ONLY.
2. CONNECTORS PROVIDED UNASSEMBLED, SHOWN ASSEMBLED.
3. WARNING: DO NOT DISCONNECT THESE CONNECTORS UNDER LOAD.
4. THESE PRODUCTS ARE RoHS COMPLIANT.

CUSTOMER DRAWING

UNLESS OTHERWISE SPECIFIED					THIS DRAWING DESCRIBES A DESIGN CONSIDERED PROPRIETARY IN NATURE, DEVELOPED AND MANUFACTURED BY SWITCHCRAFT INC. AND IS RELEASED ON A CONFIDENTIAL BASIS FOR IDENTIFICATION PURPOSES ONLY.				
1. ALL DIMENSIONS IN INCHES [mm]					SIZE	WIDTH	MULT	LBS/M	TEMPER
- TWO PLACE DECIMALS ±0.02 [0.5]					FINISH		MATERIAL		
- THREE PLACE DECIMALS ±0.005 [0.13]					SPEC No.		SPEC No.		
DO NOT SCALE DRAWING					FIRST USED ON		SCALE		
					DATE DRAWN		1:1		
					BY		APVD		
					4/4/23		4/4/23		
					CHKD		SRC		
					PNK		4/4/23		
					NAME		PART No.		
					MALE & FEMALE CABLE-END EP7C SERIES CONNECTORS		EP7C SERIES		
					REVISIONS		REV		
					A		A		

STEP 1

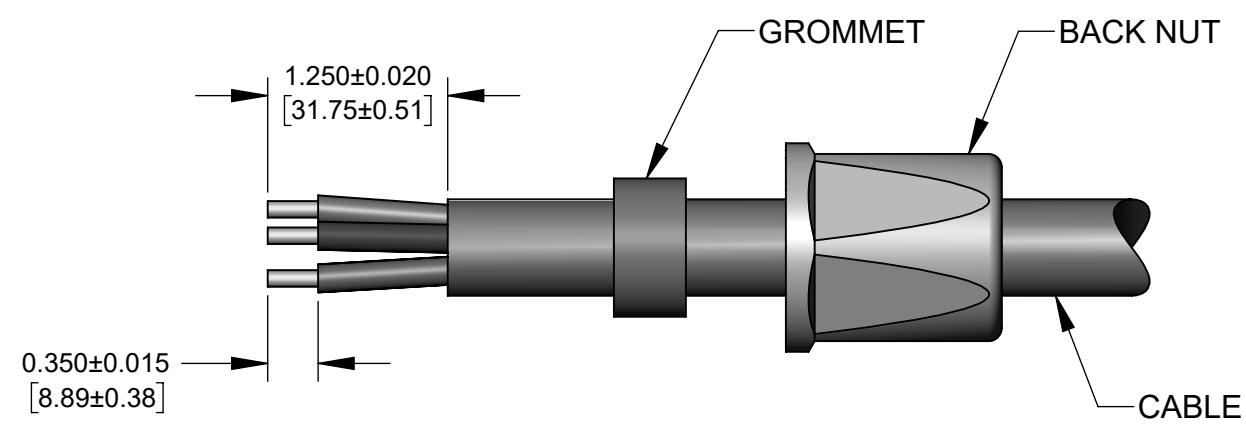

FEED THE FREE END OF CABLE THROUGH THE BACK NUT AND GROMMET IN THE ORDER SHOWN.
STRIP THE CABLE JACKET AND THE CONDUCTORS AS SHOWN.

STEP 2

5-POLE SOCKETS SHOWN

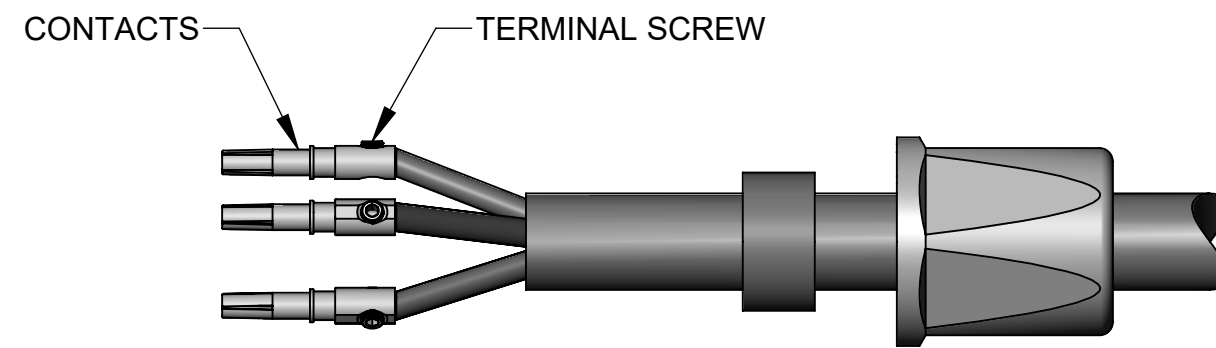

INSERT EACH STRIPPED CONDUCTOR INTO BARREL OF EACH CONTACT AND TIGHTEN TERMINAL SCREW USING A HEX DRIVE SIZE 2.
NOTE: THE PRE-ASSEMBLED TERMINAL SCREW ONTO CONTACT MAY HAVE TO BE BACKED OFF A LITTLE IN ORDER TO FIT THE 10 AWG WIRE IN THE BARREL WELL WITH EASE.

STEP 3

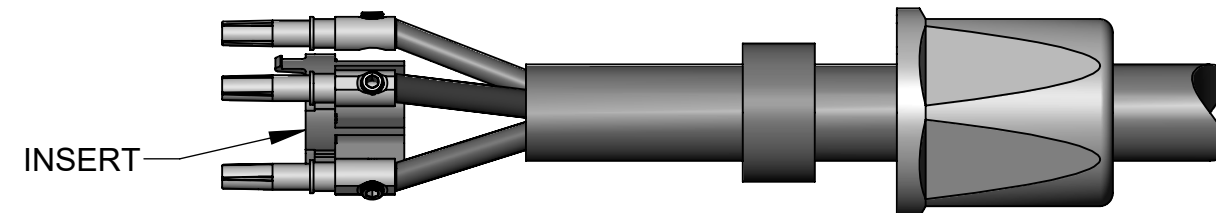
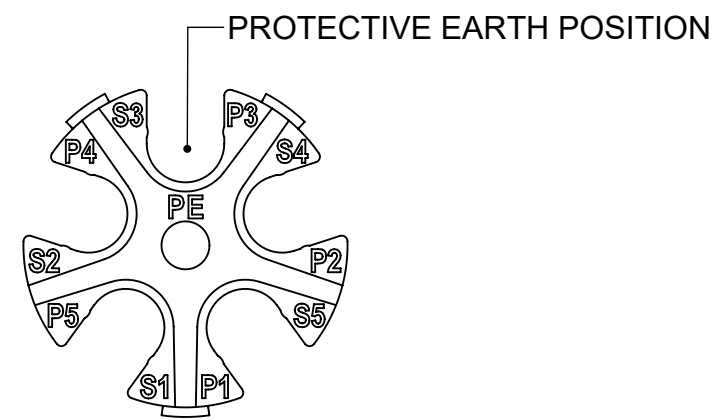

SPREAD THE WIRED CONTACTS APART RADIALLY AND POSITION INSERT BETWEEN CONTACTS PER WIRING DIAGRAM SHOWN IN FIG A.
ALIGN AND SNAP EACH CONTACT IN THE APPROPRIATE INSERT POCKET BY PUSHING FROM THE SIDE.

FIG A: INSERT (CONTACT CARRIER) REAR VIEW
S1-S5: SOCKET CONTACT POSITIONS, COUNTED CLOCKWISE
P1-P5: PIN CONTACT POSITIONS, COUNTED COUNTERCLOCKWISE

STEP 4

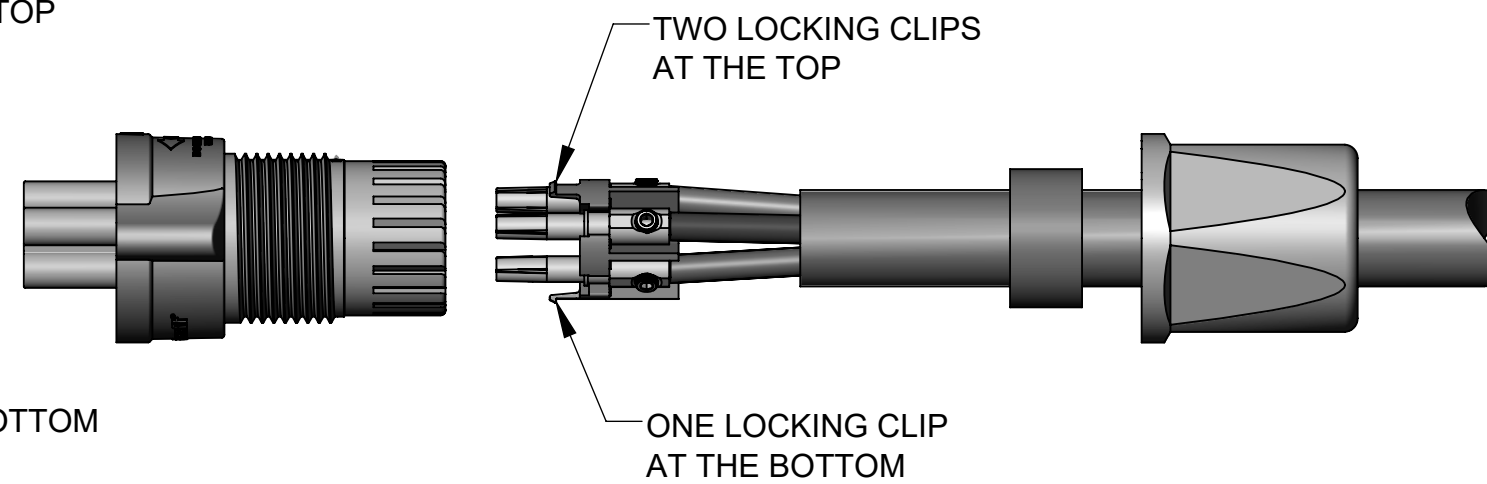
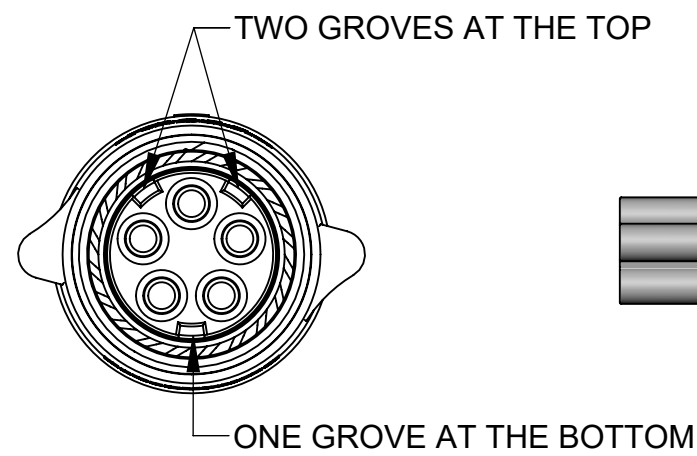

ALIGN LOCKING CLIPS OF INSERT ASSEMBLY INTO GROOVES ON THE REAR OF THE SHELL ASSEMBLY (SEE FIG B) AND PUSH FORWARD UNTIL IT LOCKS IN PLACE.

FIG B: SHELL ASSEMBLY REAR VIEW

STEP 5

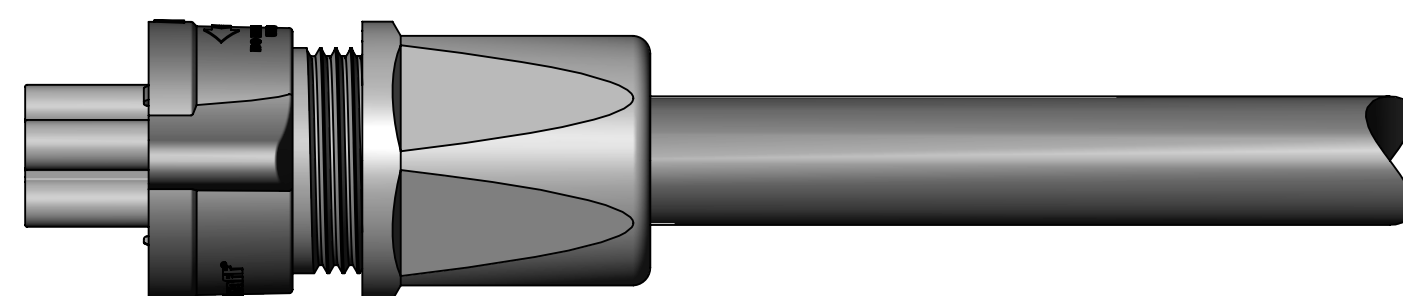

FINISHED ASSEMBLY

SLIDE GROMMET INTO THE REAR OF SHELL. TIGHTEN BACK NUT TO SECURE CABLE. A 33 mm WRENCH CAN BE USED, IF NECESSARY.

CUSTOMER DRAWING

SCALE 1:1	Switchcraft®	
DATE DRAWN 04/04/23		
DRAWN BY PNK	PART No. EP7C SERIES	REV A