

PART NO.	NO. OF PINS
17292-2PG-300	2
17292-3PG-300	3

NOTES:

- PANEL CONNECTORS TO BE PACKED IN PARTITION BOX, 100 PC PER BOX
HEX NUT AND GASKET TO BE BULKPACKED IN A SEPARATE BAG
FROM PANEL ASSEMBLY PACKAGE.
a) USE INNER BOX LABEL WITH CXA PART NUMBER, QUANTITY, LOT #
AND DATE CODE ON LABEL AS SHOWN AND PLACE ONTO THE TOP BOX
- CONTACTS ARE INSERTED INTO PANEL CONNECTOR.
- ALL DIMENSIONS ARE FOR REFERENCE ONLY UNLESS OTHERWISE SPECIFIED.

P/N: 17292-XPG-300
CONXALL
QTY.:
Lot:
Date Code:

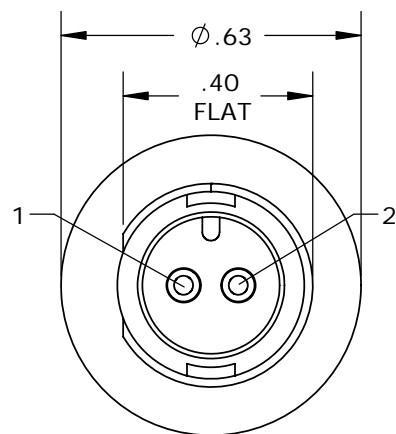

FACE VIEW
17292-2PG-300

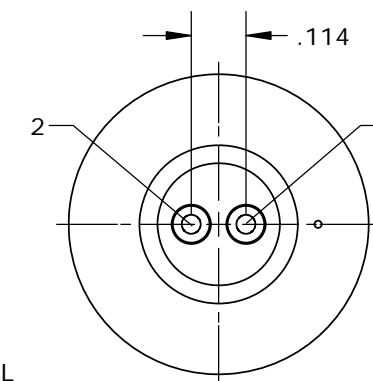
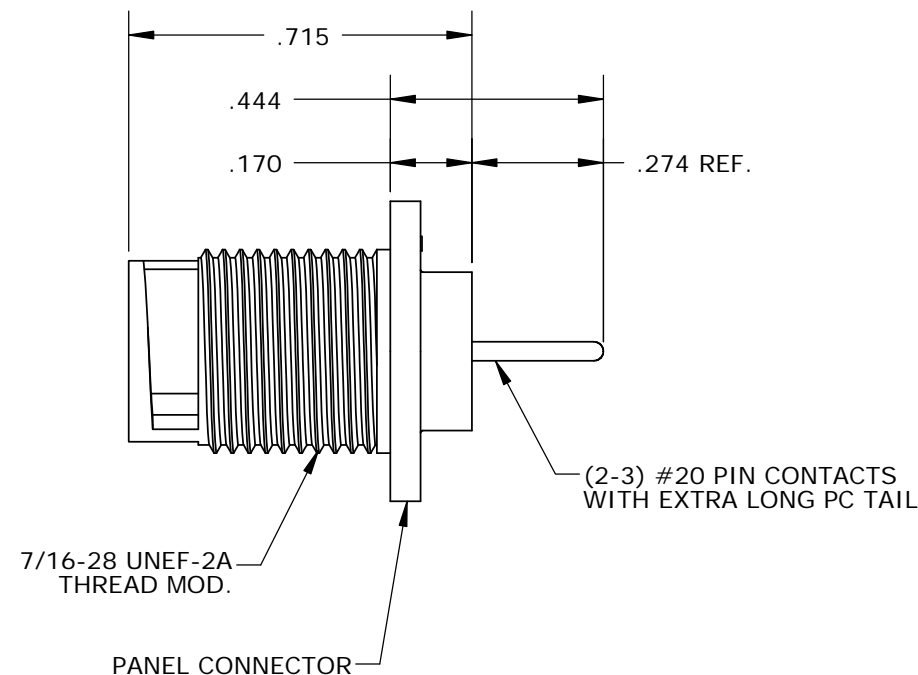
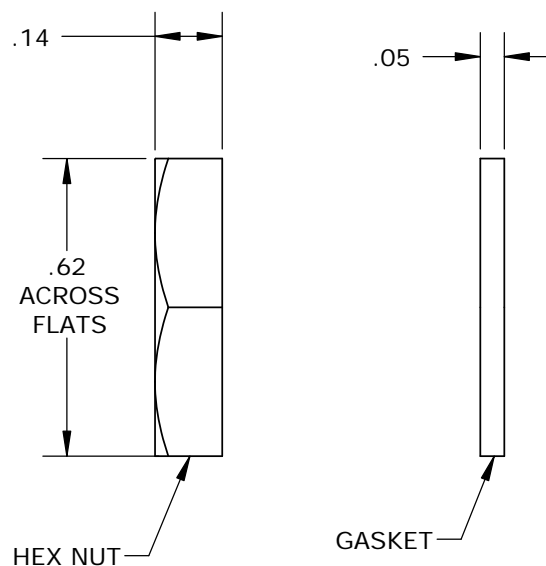

WIRE VIEW
17292-2PG-300

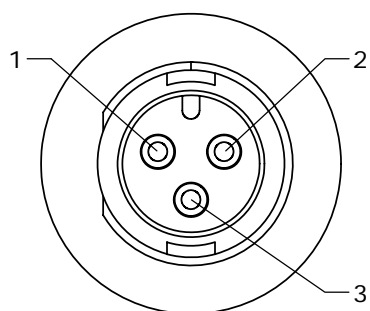

FACE VIEW
17292-3PG-300

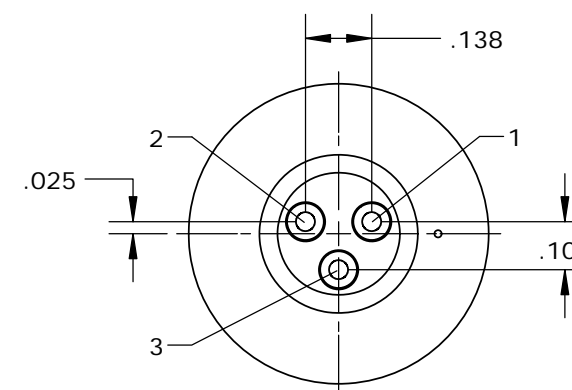

WIRE VIEW
17292-3PG-300

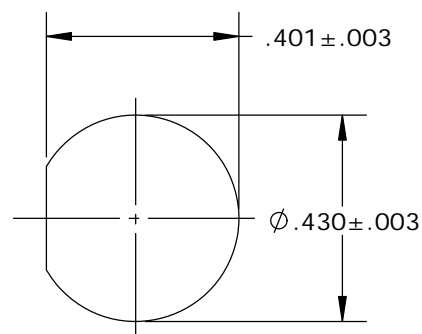

**RECOMMENDED
PANEL CUT-OUT**

CUSTOMER APPROVAL

THIS DOCUMENT CONTAINS CONFIDENTIAL INFORMATION PROPRIETARY TO CONXALL CORPORATION. ANY REPRODUCTION, DISCLOSURE, OR USE OF THIS DOCUMENT /INFORMATION IS EXPRESSLY PROHIBITED UNLESS AUTHORIZED IN WRITING BY CONXALL CORPORATION.

APPROVED BY: _____
DATE: _____

A	PAK	03-21-16	DRAWING CREATED PER DOR 15-E253SL	
REV.	INIT.	DATE	DESCRIPTION	
			ORIG. DRAWN BY: PAK	DATE: 03-21-16
ALL INFORMATION ILLUSTRATED IS THE PROPERTY OF CONXALL CORPORATION. UNAUTHORIZED DUPLICATION OR DISTRIBUTION OF THIS DOCUMENT IS PROHIBITED.			 601 E. WILDWOOD VILLA PARK, IL 60181	
ALL UNITS ARE IN FEET, INCHES, FRACTION OF INCHES AND DECIMALS.				
APPROVED BY:			TITLE: PANEL MOUNT ASSEMBLY (2-3) #20 PIN CONTACTS, XL PC TAIL MICRO-CON-X	
SCALE	SIZE	SHEET	CUSTOMER: STANDARD PRODUCT	
NTS	B	1 OF 1		
FILE: 17292-XPG-300	DIRECTORY: SLW	PART NUMBER: 17292-XPG-300	REV A	

CUSTOMER PRINT

PART NUMBER: 17292-XPG-300