

| ASS'Y P/N        | CONTACT QTY |
|------------------|-------------|
| W17282-2PG-P-300 | 2 #20       |
| W17282-3PG-P-300 | 3 #20       |

**NOTES:**

1. PARTS TO BE BULK PACKED
2. CONTACTS INSERTED INTO CONNECTOR AS SHOWN.
3. ALL DIMENSIONS ARE REFERENCE EXCEPT THOSE WITH A TOLERANCE

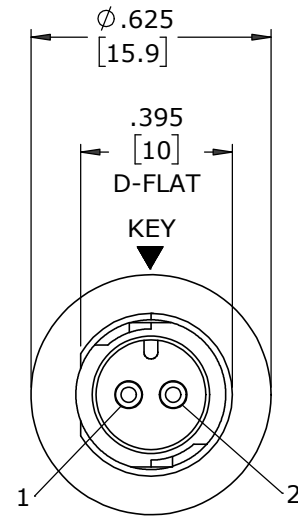

**FACE VIEW**  
W17281-2PG-P-300

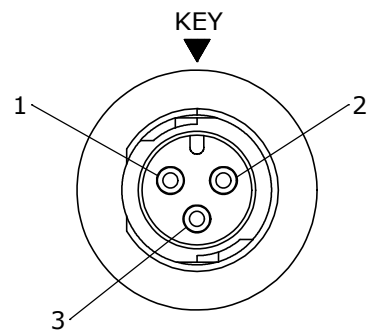

**FACE VIEW**  
W17281-3PG-P-300

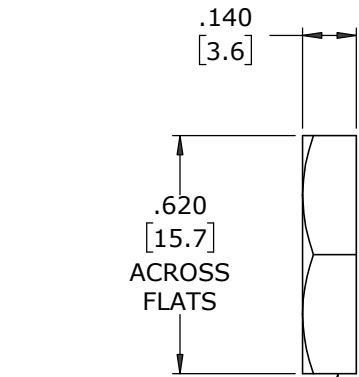

HEX NUT  
MAT'L: UV PBT, BLACK

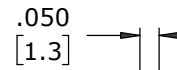

GASKET  
MAT'L: NEOPRENE, BLACK

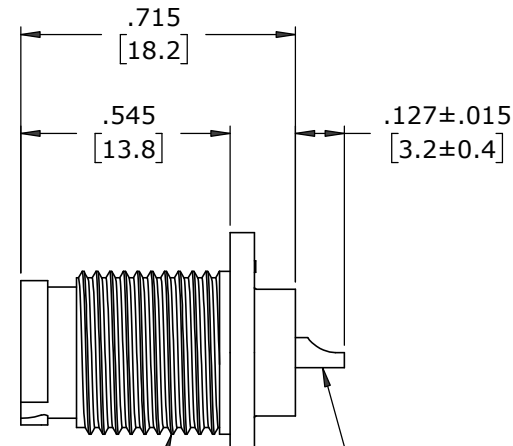

7/16-28 UNEF-2A  
MOD, THREAD  
PANEL CONNECTOR, MALE  
MAT'L: UV PBT, BLACK

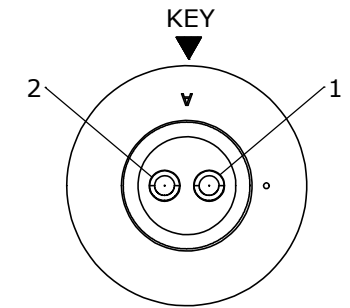

**WIRE VIEW**  
W17282-2PG-P-300

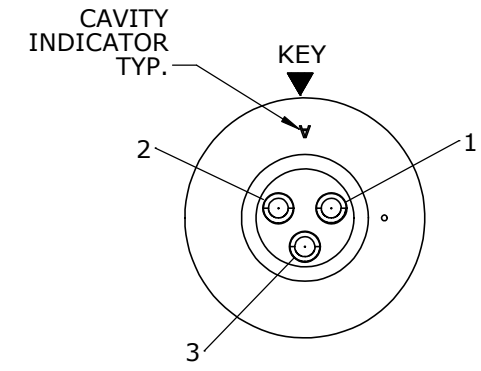

**WIRE VIEW**  
W17282-3PG-P-300

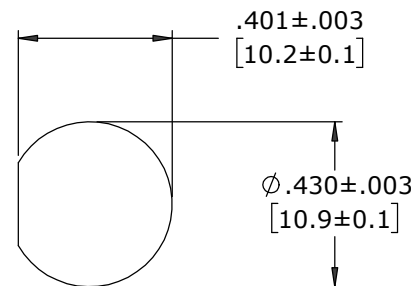

**RECOMMENDED  
PANEL CUT-OUT**

DIMENSIONS IN BRACKETS [ ] ARE IN MILLIMETERS UNLESS INDICATED

**CUSTOMER APPROVAL**

THIS DOCUMENT CONTAINS CONFIDENTIAL INFORMATION PROPRIETARY TO CONXALL CORPORATION. ANY REPRODUCTION, DISCLOSURE, OR USE OF THIS DOCUMENT /INFORMATION IS EXPRESSLY PROHIBITED UNLESS AUTHORIZED IN WRITING BY CONXALL CORPORATION.

APPROVED BY: \_\_\_\_\_  
DATE: \_\_\_\_\_

**RoHS COMPLIANT**

|  |            |  |                                |
|--|------------|--|--------------------------------|
| A  | MA         | 08-06-20   | RELEASED PER PDR 18004-2       |
|  | JGK        | 8/12/19  | DRAWING CREATED FOR PDR #18004 |
| REV.   | INIT.      | DATE   | DESCRIPTION                    |
|  | JGK        | 8/12/19  | ORIG. DRAWN BY: DATE: 8/12/19  |
| ALL INFORMATION ILLUSTRATED IS THE PROPERTY OF "CONXALL CORPORATION". UNAUTHORIZED DUPLICATION OR DISTRIBUTION OF THIS DOCUMENT IS PROHIBITED. |            |  |                                |
| ALL UNITS ARE IN FEET, INCHES, FRACTION OF INCHES AND DECIMALS.  |            |  |                                |
| APPROVED BY:   |            | TITLE: PANEL MOUNT ASSEMBLY (2-3) #20 PIN CONTACTS, SOLDER INSTA-CLICK™ MICRO-CON-X STANDARD PRODUCT |                                |
| SCALE  | SIZE       | SHEET  | CUSTOMER:                      |
| NTS  | B          | 1 OF 1   | W17282-XPG-P-300               |
| FILE:  | DIRECTORY: | PART NUMBER:   | REV                            |
| W17282-XPG-P-300   | SLW        | W17282-XPG-P-300   | A                              |



601 E. WILDWOOD VILLA PARK, IL 60181

TITLE: PANEL MOUNT ASSEMBLY (2-3) #20 PIN CONTACTS, SOLDER INSTA-CLICK™ MICRO-CON-X STANDARD PRODUCT

CUSTOMER: W17282-XPG-P-300

CUSTOMER PRINT

PART NUMBER: W17282-XPG-P-300