

TYPICAL CABLE-TO-CABLE PIN (MALE)  
(TS2L7M26B SHOWN HERE)

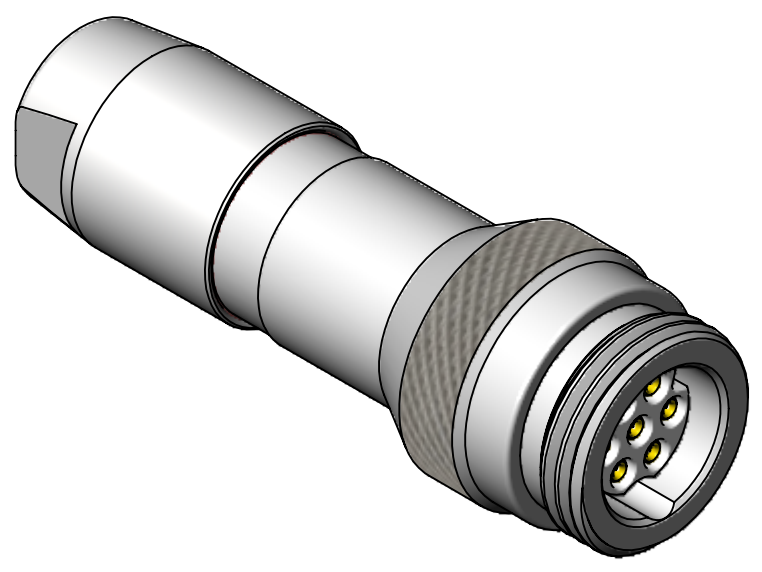

TYPICAL CABLE-TO-CABLE SOCKET (FEMALE)  
(TS2L7F26B SHOWN HERE)

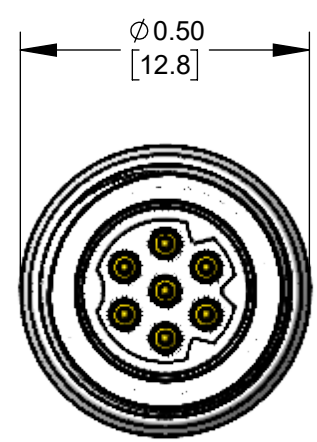

TS2L7M26B SHOWN HERE

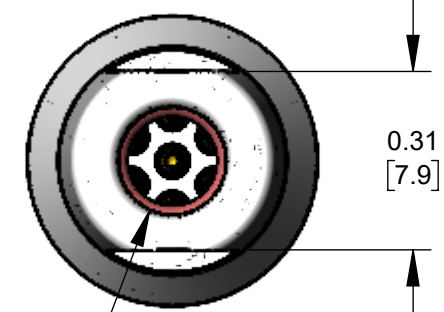
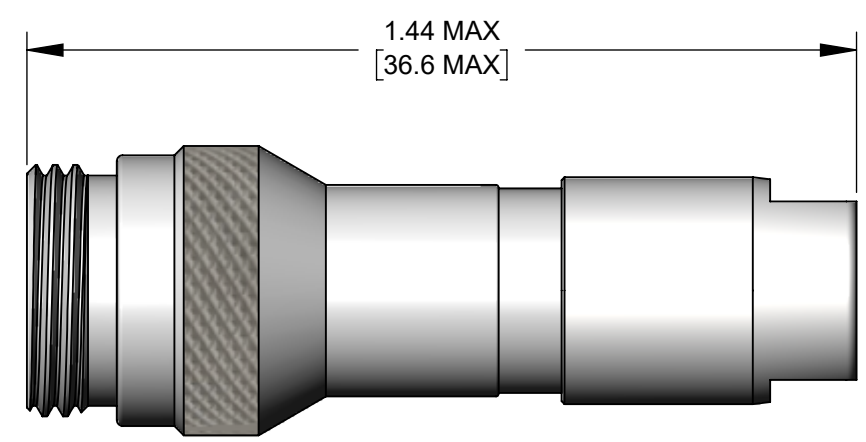

BACK NUT DIA.  
SIZE A: 0.150 [3.81] DIA.  
SIZE B: 0.190 [4.83] DIA.  
SIZE C: 0.230 [5.84] DIA.

ALL DIMENSIONS FOR REFERENCE ONLY.  
CONNECTORS PROVIDED UNASSEMBLED, SHOWN ASSEMBLED HERE.

TOOL	TOOL TYPE	POSITIONER	CONTACT SIZE	WIRE SIZES
EN3CR	HAND CRIMP TOOL	EN2POS20	20 and 22	20 and 22 AWG
		EN3POS26	26	26, 28, and 30 AWG
EN3CRAUTO	PNEUMATIC CRIMP TOOL	EN2POS20	20 and 22	20 and 22 AWG
		EN3POS26	26	26, 28, and 30 AWG
EN2CRL	HAND CRIMP TOOL LARGE FRAME	EN2POS20L	20 and 22	20, 22, 24, and 26 AWG
EN2CRAUTOL	PNEUMATIC CRIMP TOOL LARGE FRAME			
INSTOOL20	CONTACT INSERTION	--	20	20, 22, 24, and 26 AWG
INSTOOL26		--	26	26, 28, and 30 AWG
REMTOOL20	CONTACT EXTRACTION	--	20	20, 22, 24, and 26 AWG
REMTOOL26		--	26	26, 28, and 30 AWG

**TS2 L**

TS2 SERIES  
L - CABLE-TO-CABLE CONNECTOR

KIT PACKAGING OPTION:  
K - ONE UNIT / BAG

# OF CONTACTS:  
2-5 FOR #20 CONTACTS  
6-9 FOR #26 CONTACTS

GENDER:  
M - MALE (PIN)  
F - FEMALE (SOCKET)

CLAMP SET PER CABLE O.D. RANGE:  
A - 0.110 - 0.140 [2.8 - 3.6]  
B - 0.140 - 0.180 [3.6 - 4.6]  
C - 0.180 - 0.216 [4.6 - 5.5]

CONTACT SIZE:  
20 - 20, 22, 24, 26 AWG WIRES  
26 - 26, 28, 30 AWG WIRES

REFER TO "TS2C SERIES" DRAWING FOR MATING CABLE-END CONNECTORS.

SPECIFICATIONS:	
<b>MECHANICAL</b>	
Mating / Locking Type:	Threaded Coupling
Life	5,000 cycles minimum
Operating Forces	10 lb. [44.5 N] maximum Insertion or Withdrawal
Vibration	Mil-Std 202G Method 201A
Panel-Mount Hex Nut Torque	40 in-lb [4.5 Nm] maximum
Cable Securing System:	Threaded on metal Clamp
<b>ELECTRICAL</b>	
Voltage Rating	125 V AC/DC for 2-5 contact arrangements 30 V AC/DC for 6-9 contact arrangements
Current Rating	Refer to Current Carry Capacity Table
Insulation Resistance	1000 MΩ minimum
Contact Resistance	10 mΩ typical
EMI Shielding	360°
<b>ENVIRONMENTAL</b>	
Temperature Limits	-40°C to +135°C (-40°F to +275°F)
Operating Temperature Range	Refer to Current Carry Capacity Table
Moisture Resistance	Mil-Std 202G Method 106G
Insulation Resistance	Mil-Std 202G Method 302
Thermal Shock	Mil-Std 202G Method 107G
Salt Atmosphere (Corrosion)	Mil-Std 202G Method 101E
Ingress Protection Ratings	IP66, IP67, IP68 (6 ft. for 24 hours) per IEC60529, NEMA 250 6P
<b>MATERIAL</b>	
Outer Shell Metal components	Copper Alloy, electroless nickel plated
Hex Nut & Inner Metal components	Copper Alloy, nickel plated
Electrical Insulator	Medical Technology LCP, natural
Seal O-rings	Thermoplastic Elastomer
Contacts Assembly	Copper Alloy, gold plated with Stainless Steel locking clip

Contacts	Wire (awg)	Current Rating (A) at Operating Temperature (°C)					Minimum Test Voltage (V rms)	Voltage (V rms) tested per UL2238
		45°C max.	65°C max.	85°C max.	100°C max.	110°C max.		
2 #20	20	10	9	8	7*	6	1300	125
	22	8.5	7.5	7.5	5.5*	4.5		
	24	7	6	5	4.5*	3.5		
	26	4	4	3.5	3.5*	2.5		
3 #20	20	9.5	8.5	7.5	6.5*	5		
	22	8	7	6	5*	4		
	24	6	5.5	4.5	4*	3		
	26	3.5	3.5	3	3*	2.5		
4 #20	20	9	8	7	6*	5		
	22	7.5	6.5	5.5	4.5*	3.5		
	24	5	4.5	4	3.5*	2.5		
	26	3	3	2.5	2.5*	2		
5 #20	20	8	7.5	6.5	5.5*	4.5		
	22	6.5	5.5	5	4*	3		
	24	4.5	4	3.5	3*	2.5		
	26	2.5	2.5	2	2*	1.5		
6-7 #26	26	2.5	2.5	2	2*	1.5		
	28	2	2	1.5	1.5*	1		
	30	1.5	1.5	1	1*	.5		
	26	2	2	1.5	1.5*	1		
8-9 #26	28	1.5	1.5	1	1*	.5		
	30	1	1	.5	.5*	.5		

\*Temperature Rise does not exceed 30°C when tested according to UL2238. All other recommended current ratings are based on the Relative Thermal Index of the insulating material.

CUSTOMER DRAWING

UNLESS OTHERWISE SPECIFIED

1. ALL DIMENSIONS IN INCHES [mm]  
- TWO PLACE DECIMALS ±0.02 [0.5]  
- THREE PLACE DECIMALS ±0.005 [0.13]

REV	ECO NUMBER	DATE	BY	APVD
OB	10 lb WAS 5 lb	09/22/16	PNK	SRC
OA	PRELIMINARY	04/20/16	PNK	SRC

REVISIONS

DO NOT SCALE DRAWING

SolidWorks CAD File

THIS DRAWING DESCRIBES A DESIGN CONSIDERED PROPRIETARY IN NATURE, DEVELOPED AND MANUFACTURED BY SWITCHCRAFT INC. AND IS RELEASED ON A CONFIDENTIAL BASIS FOR IDENTIFICATION PURPOSES ONLY.

SIZE	WIDTH	MULT	LBS/M	TEMPER

FINISH: FIRST USED ON

SCALE: 3:1

DATE DRAWN: 04/20/16 BY: PNK CHKD: PNK APVD: SRC

NAME: CABLE-TO-CABLE TS2 SERIES CONNECTOR PART No. TS2L SERIES REV: 0B

Switchcraft®

SHEET 1 OF 2

STEP 1

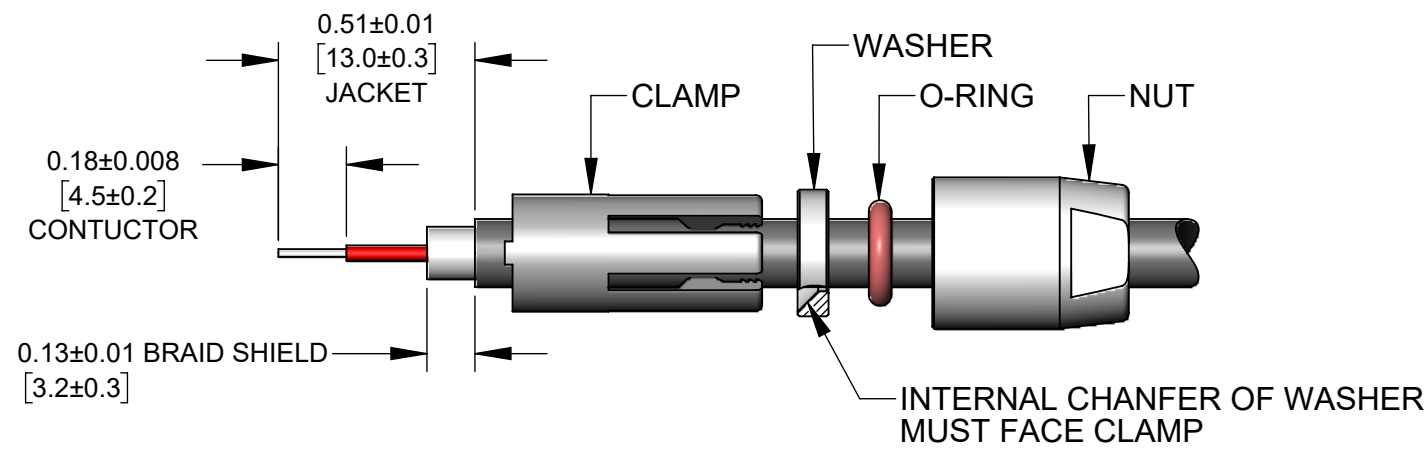

FEED THE FREE END OF CABLE THROUGH THE NUT, O-RING, WASHER, AND CLAMP IN THE ORDER SHOWN.  
STRIP THE CABLE JACKET, THE CONDUCTORS, AND THE CABLE SHIELDING AS SHOWN.

STEP 2

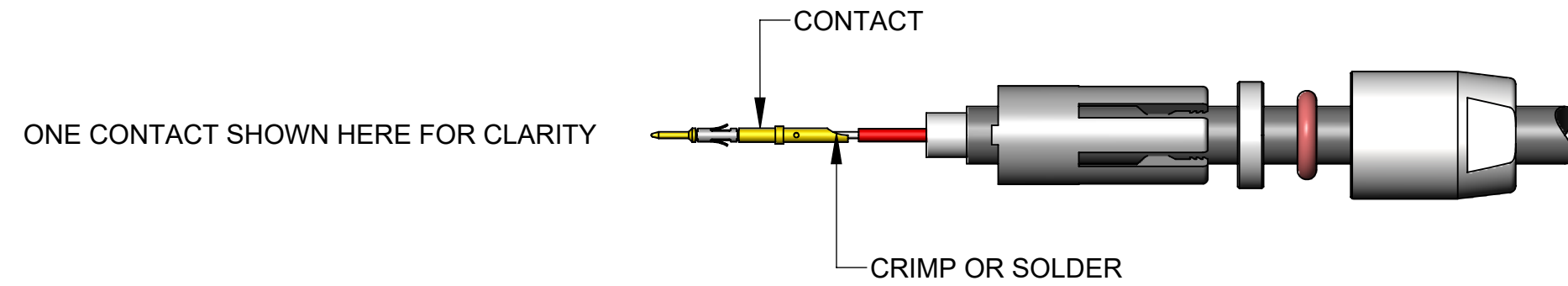

CRIMP CONDUCTORS TO CONTACTS USING HAND OR PNEUMATIC CRIMP TOOL\* WITH CRIMP POSITIONER\* SET PER CONTACT SIZE AND WIRE GAGE.  
IF SOLDERING, IT IS RECOMMENDED TO SOLDER CONDUCTORS TO CONTACTS BEFORE INTALLATION.

STEP 3

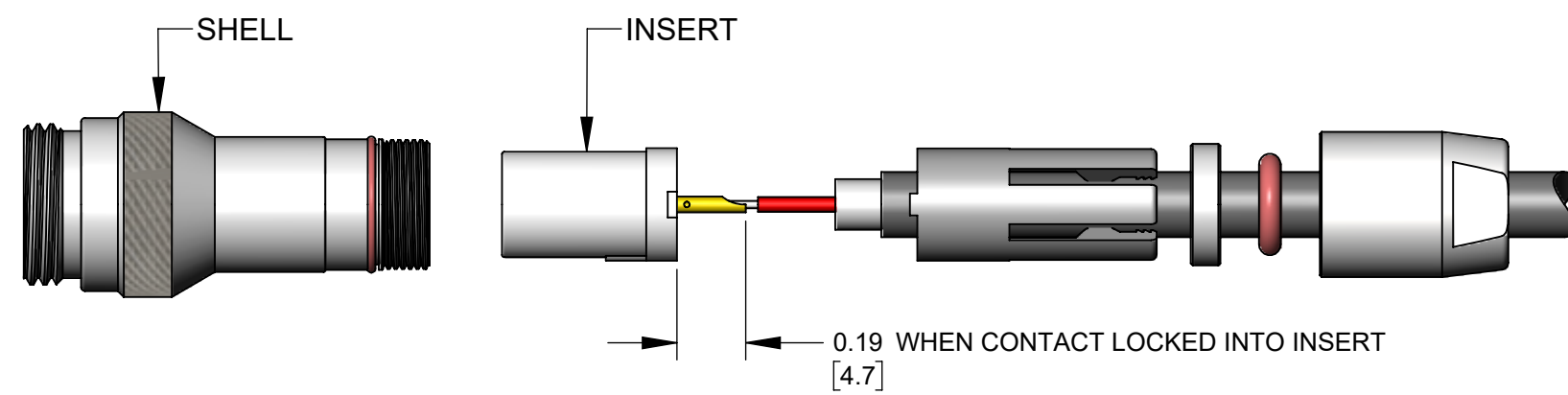

GUIDE EACH WIRED CONTACT INTO INSERT HOLE AND PUSH UNTIL CONTACT SNAPS IN PLACE. USE INSERTION TOOL\* IF NECESSARY.  
COLORED CONDUCTORS CAN BE ASSIGNED TO CONTACT POSITION NUMBERS AS DESIRED.  
TO REMOVE A CONTACT, INSERT THE EXTRACTION TOOL\* FROM THE FRONT OF INSERT AND LIGHTLY PRESS THE SPRING LOADED PLUNGER INWARD TO PUSH THE CONTACT OUT.

STEP 4

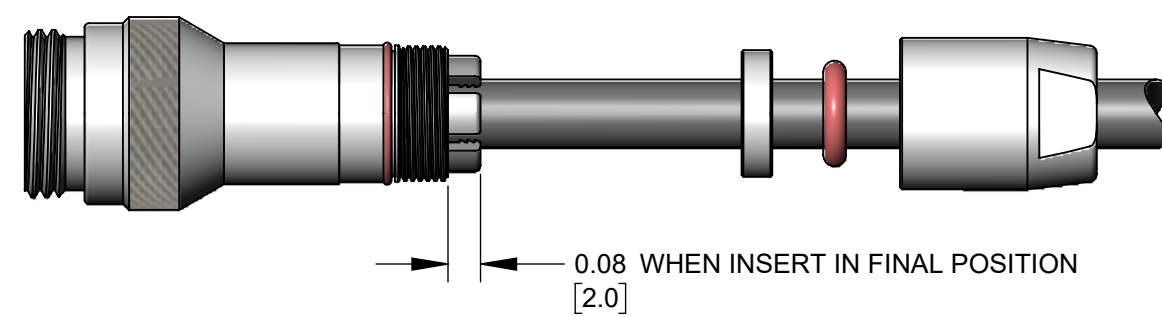

ALIGN INSERT ASSEMBLY INTO SHELL FOLLOWED BY THE CLAMP. PUSH CLAMP LIGHTLY FORWARD AND ROTATE UNTIL THE ASSEMBLY SNAPS IN THE FINAL POSITION SHOWN.

STEP 5

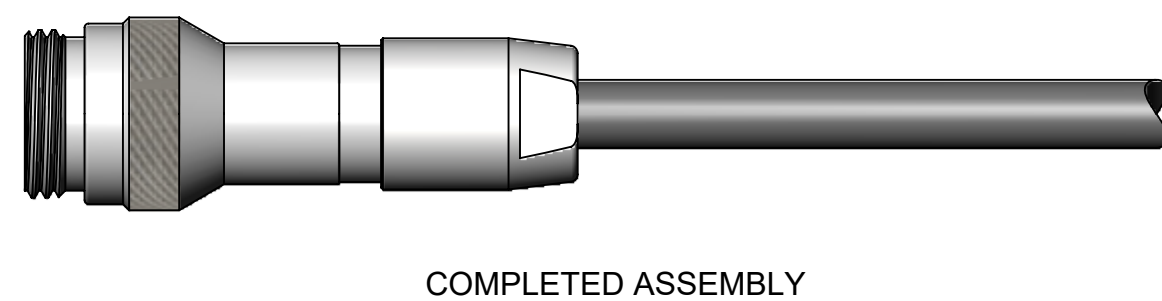

SLIDE WASHER, O-RING, AND NUT AGAINST CLAMP AND THREAD NUT ON UNTIL TIGHT - NOT TO EXCEED 9 IN-LB [1 Nm] TORQUE. A 5/16" [8mm] WRENCH CAN BE USED, IF NECESSARY.

\*REFER TO TOOLS TABLE ON THIS DRAWING FOR SELECTION OF TOOLS PER CONTACT AND WIRE SIZE.

**TS2 SERIES CABLE-TO-CABLE  
FIELD ASSEMBLY INSTRUCTIONS**

SCALE 2:1	Switchcraft®	
DATE DRAWN 04/20/16		
DRAWN BY PNK	PART No. TS2L_SERIES_CD	REV 0A