

**NOTES:**

1. ALL PARTS TO BE BULK PACKED
2. CONTACTS INSERTED INTO CONNECTOR.
3. BLACK EPOXY SEALED ON BACK SIDE OF CONNECTOR
4. ALL DIMENSIONS ARE REFERENCE EXCEPT THOSE WITH A TOLERANCE.
5. SEE DRAWING HPMGSTD FOR HOLE PATTERN

CUSTOMER PRINT

PART NUMBER: 24282-31SG-3ES

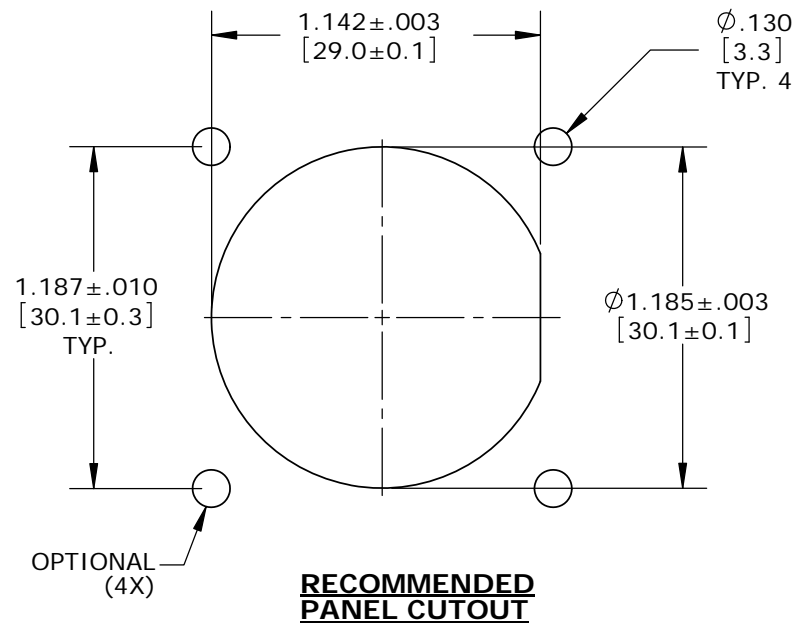
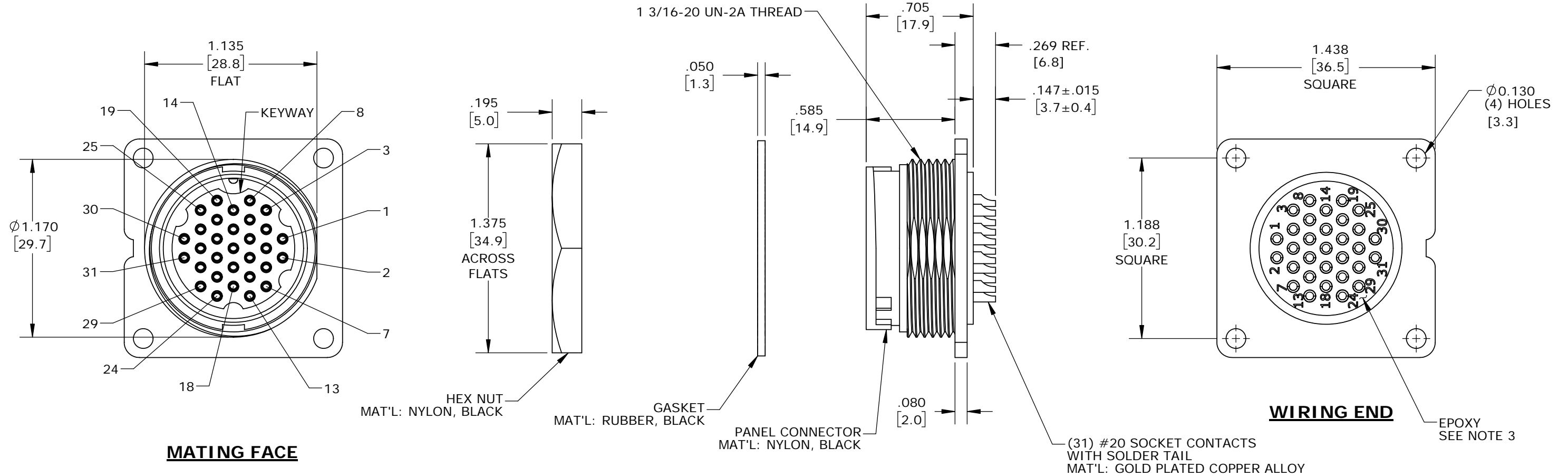

DIMENSIONS IN BRACKET [ ] ARE METRIC.

**CUSTOMER APPROVAL**

THIS DOCUMENT CONTAINS CONFIDENTIAL INFORMATION PROPRIETARY TO CONXALL CORPORATION. ANY REPRODUCTION, DISCLOSURE, OR USE OF THIS DOCUMENT / INFORMATION IS EXPRESSLY PROHIBITED UNLESS AUTHORIZED IN WRITING BY CONXALL CORPORATION.

APPROVED BY: \_\_\_\_\_

DATE: \_\_\_\_\_

|   |                |          |  |
|---|----------------|----------|--|
| A   | MA             | 11-29-17 | CREATED DRAWING PER ECR 9236   |
| REV.  | INIT.          | DATE     | DESCRIPTION  |
|   | MA             | 11-29-17 |  |
| <small>ALL INFORMATION ILLUSTRATED IS THE PROPERTY OF "CONXALL CORPORATION". UNAUTHORIZED DUPLICATION OR DISTRIBUTION OF THIS DOCUMENT IS PROHIBITED.</small> |                |          | <p>601 E. WILDWOOD VILLA PARK, IL 60181</p>  |
| <small>ALL UNITS ARE IN FEET, INCHES, FRACTION OF INCHES AND DECIMALS.</small>  |                |          |  |
| <small>UNLESS OTHERWISE SPECIFIED TOLERANCES:<br/>3 PLACE DECIMALS ±.005<br/>ANGLES ±1°<br/>FRACTIONS ±1/16</small>   |                |          | <b>TITLE:</b> CONNECTOR ASSEMBLY<br>31 #20 SOCKET CONTACT<br>MEGA-CON-X<br><b>CUSTOMER:</b> STANDARD PRODUCT |
| FILE:   | SIZE:          | SHEET:   |  |
| 24282-31SG-3ES  | B              | 1 OF 1   |  |
| DIRECTORY:  | PART NUMBER:   | REV      |  |
| SLW   | 24282-31SG-3ES | A        |  |