

NOTES:

- ① FINISHED PRODUCT TO BE BOXED.
GASKETS AND HEX NUTS MAY BE PACKAGED SEPERATELY.
- ② INSTALL CONTACTS INTO CONNECTOR AS SHOWN.
- ③ ALL DIMENSIONS ARE REFERENCE EXCEPT THOSE WITH A TOLERANCE.
- ④ SEE DRAWING HPMGSTD FOR HOLE PATTERN.

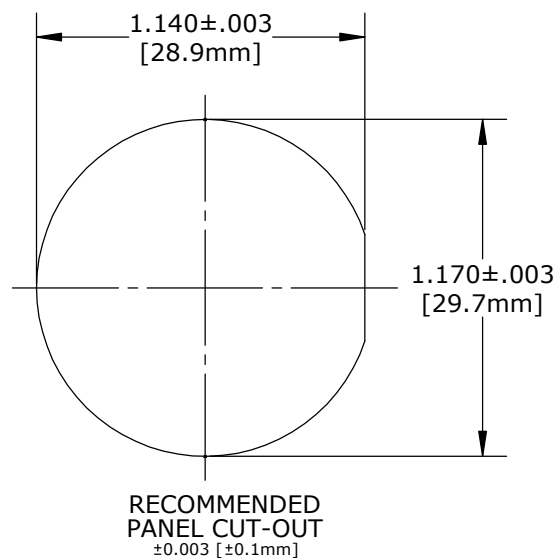
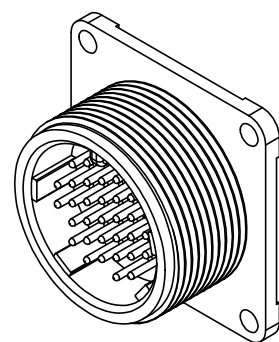
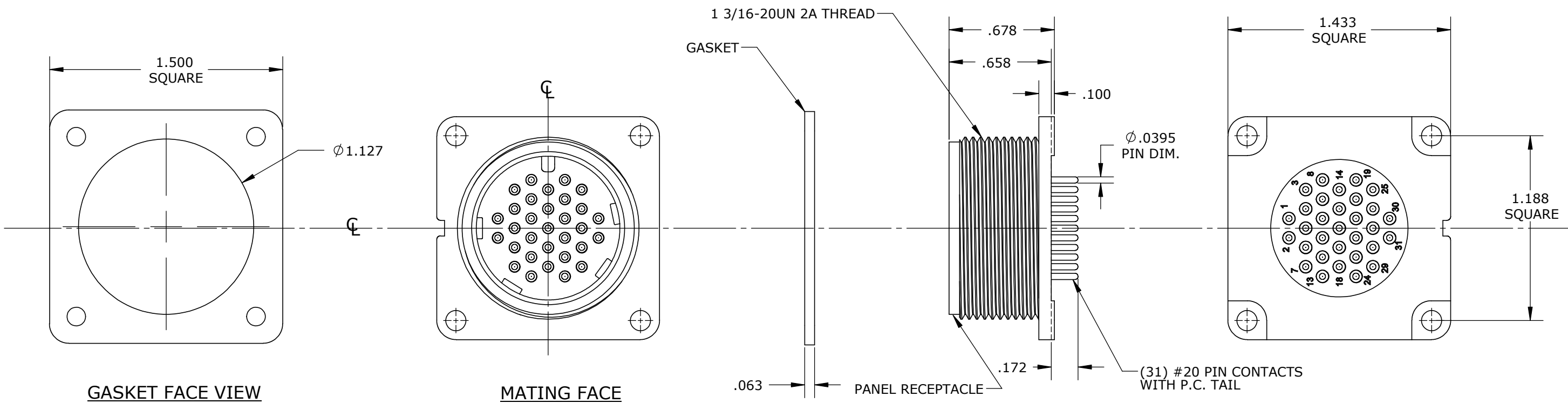

CUSTOMER APPROVAL

THIS DOCUMENT CONTAINS CONFIDENTIAL INFORMATION PROPRIETARY TO CONXALL CORPORATION. ANY REPRODUCTION, DISCLOSURE, OR USE OF THIS DOCUMENT /INFORMATION IS EXPRESSLY PROHIBITED UNLESS AUTHORIZED IN WRITING BY CONXALL CORPORATION.

APPROVED BY: _____
DATE: _____

D	SS	05-12-21	PACKAGING WAS 50 PCS PER BAG PER ECR 9586
C	PD	07-12-11	UPDATE MANUFACTURING DRAWING PER ECR 7914
B	AN	04-08-08	REVISED DIMENSIONS, ADDED GASKET FACE VIEW, CONVERTED TO SOLIDWORKS. PER ECR 6820
A	AN	11-27-06	DRAWING CREATED PER ECR 6327
REV.	INIT.	DATE	DESCRIPTION
ALL INFORMATION ILLUSTRATED IS THE PROPERTY OF "CONXALL CORPORATION". UNAUTHORIZED DUPLICATION OR DISTRIBUTION OF THIS DOCUMENT IS PROHIBITED.		ORIG. DRAWN BY: AN	DATE: 11-27-06
ALL UNITS ARE IN FEET, INCHES, FRACTION OF INCHES AND DECIMALS. UNLESS OTHERWISE SPECIFIED TOLERANCES: 3 PLACE DECIMALS ±.005 ANGLES ±1° FRACTIONS ±1/16		CHECKED BY:	 601 E. WILDWOOD VILLA PARK, IL 60181 TITLE: PANEL CONNECTOR ASS'Y 31 #20 PIN CONTACTS MEGA-CON-X STANDARD PRODUCT
▽ = CRITICAL CHARACTERISTIC FLAG PER SPEC. XXXX		APPROVED BY:	
SCALE	SIZE	SHEET	CUSTOMER:
NTS	B	1 OF 1	STANDARD PRODUCT
FILE:	DIRECTORY:	PART NUMBER:	REV
24281-31PGT-300	SLW	24281-31PGT-300	D