

CUSTOMER PRINT

PART NUMBER: 17982-XPG-300

ASS'Y P/N	CONTACT QTY.	KEY STYLE
17982-5PG-300	5 - #26	A-KEY
17982-6PG-300	6 - #26	B-KEY
17982-7PG-300	7 - #26	A-KEY

NUMBER OF CONTACTS

- NOTES:**
1. ALL PARTS ARE TO BE BULK PACKED.
 2. CONTACTS ARE ASSEMBLED INTO PANEL CONNECTOR.
 3. SOLDER CUPS ARE TO BE FACING OUTWARD RADIALLY. CENTER CONTACT SHOULD BE FACING BETWEEN POSITIONS 1 & 6.
 4. ALL DIMENSIONS ARE REFERENCE EXCEPT THOSE WITH A TOLERANCE

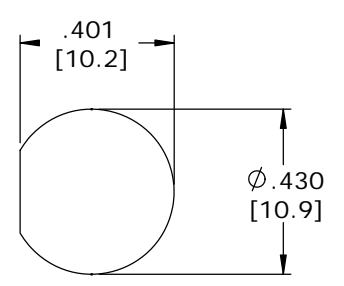
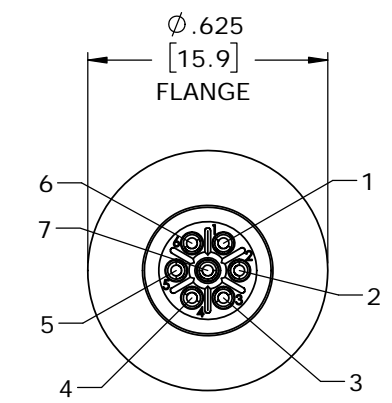
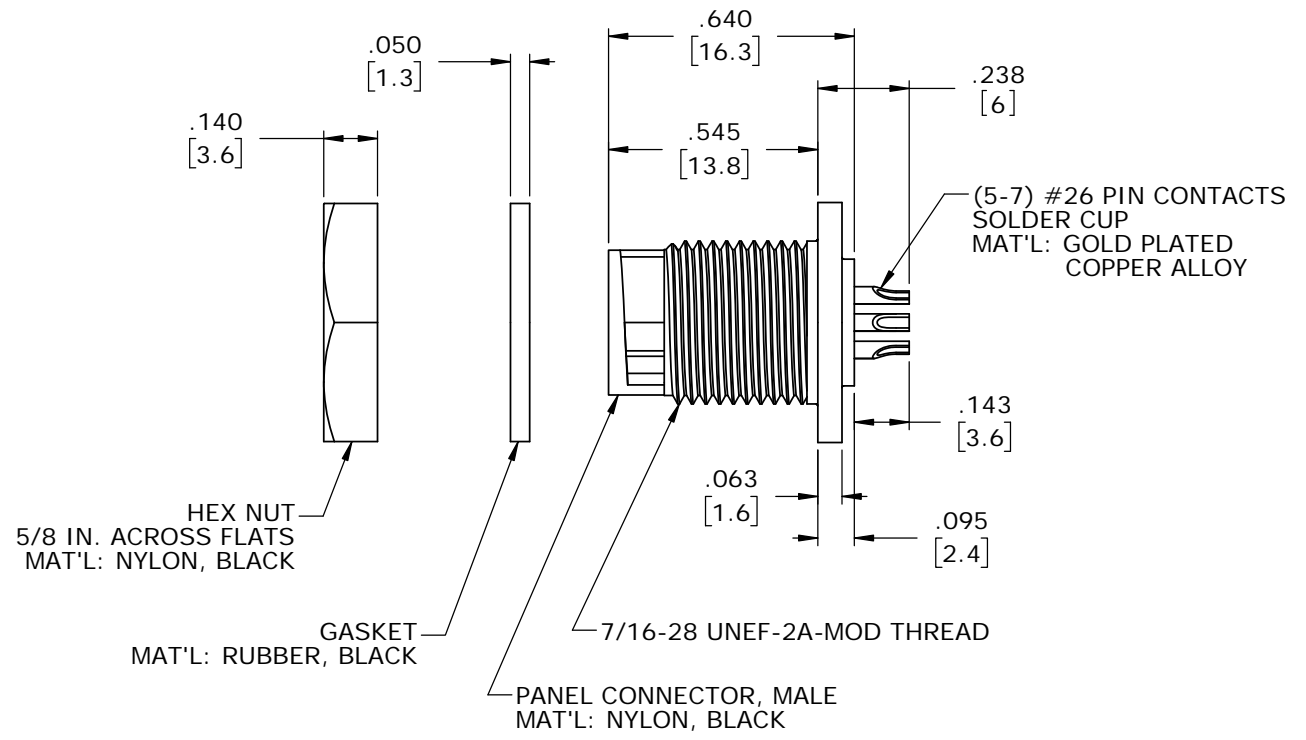
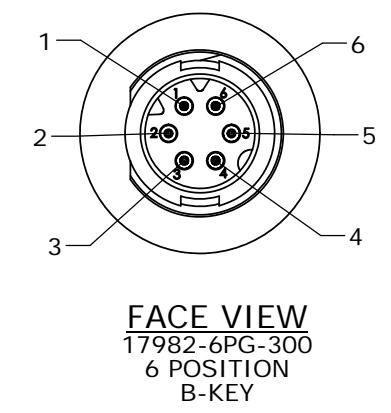
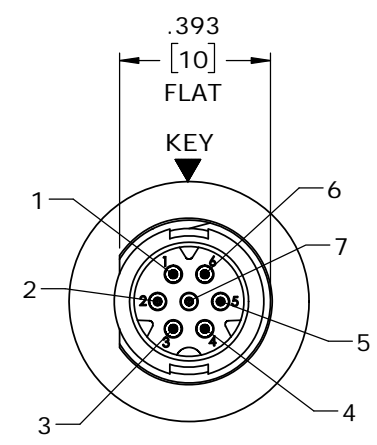
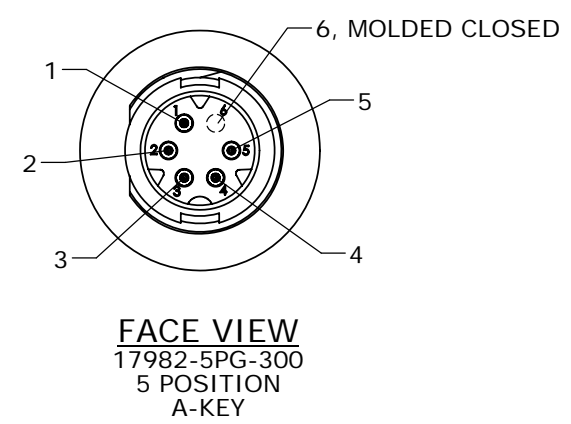

**RECOMMENDED
PANEL CUT-OUT
TOLERANCE: ±.003**

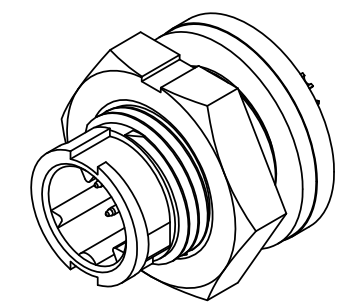

DIMENSIONS IN BRACKETS [] ARE IN MILLIMETERS

CUSTOMER APPROVAL				
THIS DOCUMENT CONTAINS CONFIDENTIAL INFORMATION PROPRIETARY TO CONXALL CORPORATION. ANY REPRODUCTION, DISCLOSURE, OR USE OF THIS DOCUMENT /INFORMATION IS EXPRESSLY PROHIBITED UNLESS AUTHORIZED IN WRITING BY CONXALL CORPORATION.				
APPROVED BY: _____	MA	09-11-18	UPDATED MFG DRAWING PER ECR 9211-6	
DATE: _____	AN	11-07-11	DRAWING CREATED PER DOR 11-E149SL	
<small>ALL INFORMATION ILLUSTRATED IS THE PROPERTY OF CONXALL CORPORATION. UNAUTHORIZED DUPLICATION OR DISTRIBUTION OF THIS DOCUMENT IS PROHIBITED.</small> <small>ALL UNITS ARE IN FEET, INCHES, FRACTION OF INCHES AND DECIMALS.</small> <small>UNLESS OTHERWISE SPECIFIED TOLERANCES: 3 PLACE DECIMALS ±.010 ANGLES ±1° FRACTIONS ±1/16 - CRITICAL CHARACTERISTIC FLAG PER SPEC. XXXX</small>	REV.	INIT.	DATE	
	PAK		07/19/11	
	<small>ORIG. DRAWN BY: DATE:</small> <small>CHECKED BY:</small>			 601 E. WILDWOOD VILLA PARK, IL 60181
	<small>APPROVED BY:</small>			
SCALE	SIZE	SHEET		
NTS	B	1 OF 1		
FILE:	DIRECTORY:	PART NUMBER:	REV	
17982-XPG-300	SLW	17982-XPG-300	B	

RoHS COMPLIANT