

**NOTES:**

1. FINISHED PRODUCT TO BE BULK PACKAGED 100 PCS PER BAG  
ALL GASKETS AND HEX NUTS TO BE BULK PACKED.
2. CONTACTS TO BE INSERTED INTO CONNECTOR AS SHOWN.
3. SEE DRAWING HPMXSTD FOR HOLE PATTERN.
4. APPLY BLACK EPOXY TO BACK END OF PANEL CONNECTOR.

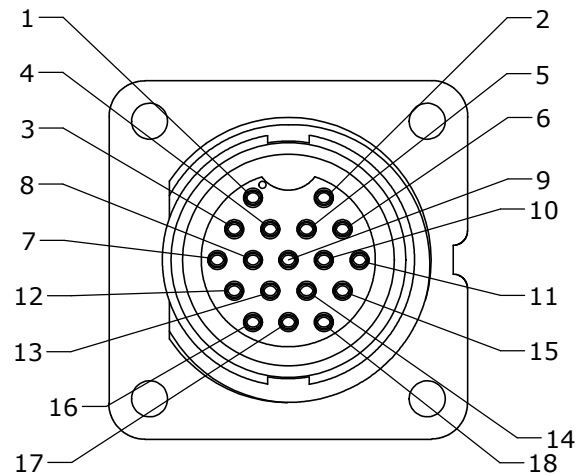

**FACE VIEW**

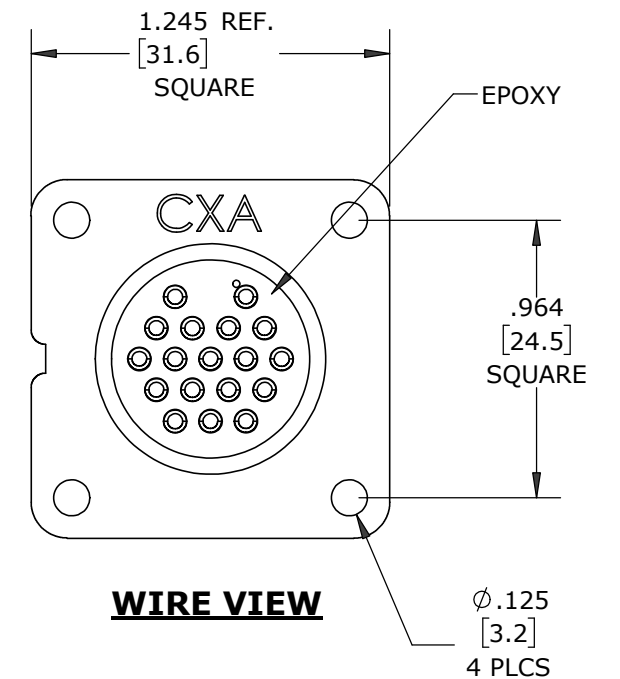
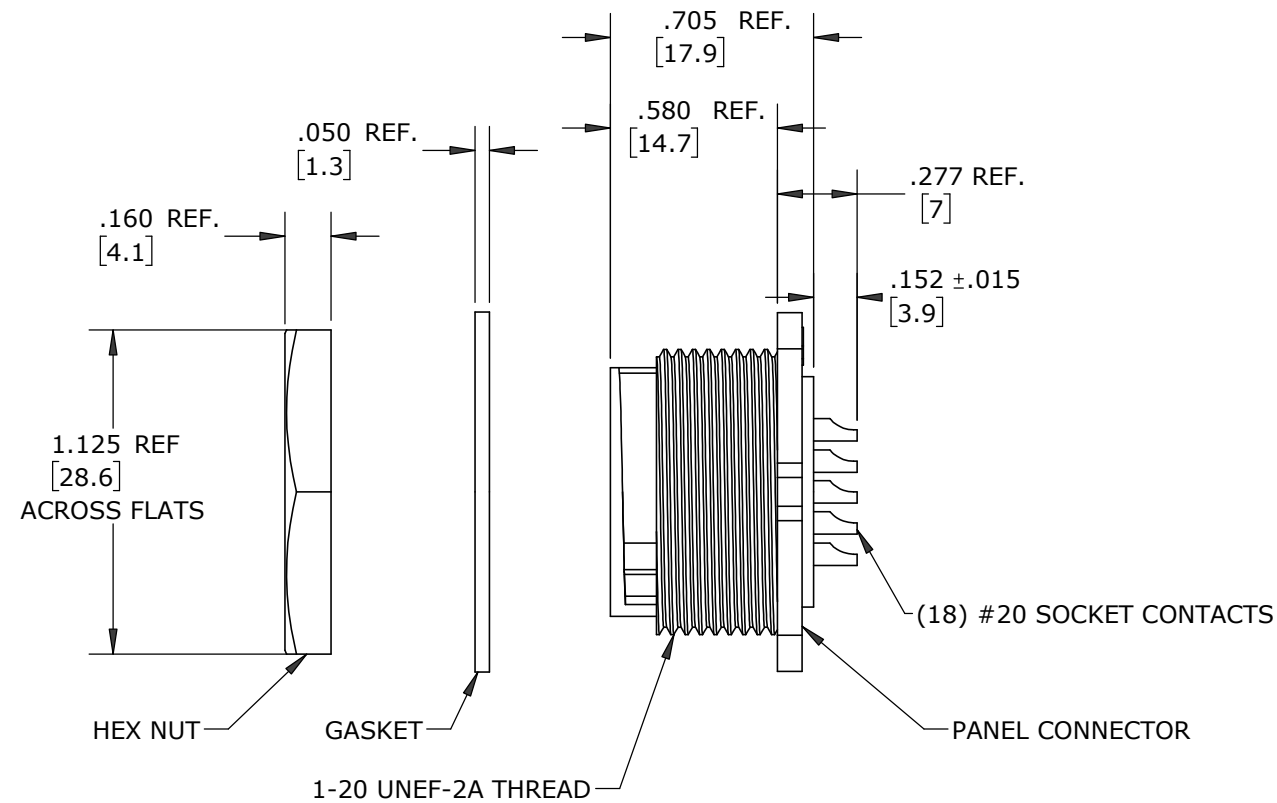

**WIRE VIEW**

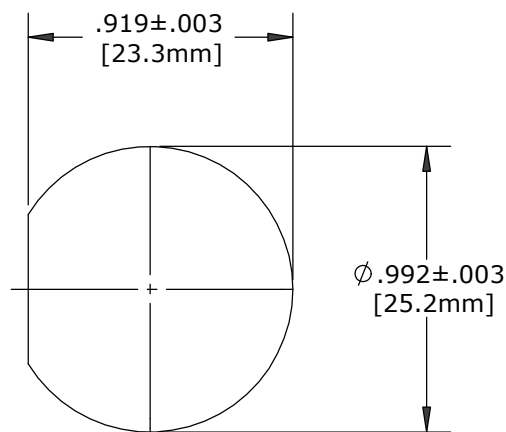

RECOMMENDED  
PANEL CUTOUT

DIMENSIONS IN BRACKETS [ ] ARE METRIC

CUSTOMER APPROVAL	
THIS DOCUMENT CONTAINS CONFIDENTIAL INFORMATION PROPRIETARY TO CONXALL CORPORATION. ANY REPRODUCTION, DISCLOSURE, OR USE OF THIS DOCUMENT /INFORMATION IS EXPRESSLY PROHIBITED UNLESS AUTHORIZED IN WRITING BY CONXALL CORPORATION.	
APPROVED BY: _____	DATE: _____

**RoHS COMPLIANT**

A	SS	06-10-21	DRAWING CREATED PER DOR 15-E253SL #44	
REV.	INIT.	DATE	DESCRIPTION	
	SS	06-10-21	ORIG. DRAWN BY: SS	DATE: 06-10-21
ALL INFORMATION ILLUSTRATED IS THE PROPERTY OF "CONXALL CORPORATION". UNAUTHORIZED DUPLICATION OR DISTRIBUTION OF THIS DOCUMENT IS PROHIBITED.			 601 E. WILDWOOD VILLA PARK, IL 60181	
ALL UNITS ARE IN FEET, INCHES, FRACTION OF INCHES AND DECIMALS.				
APPROVED BY: _____			TITLE: PANEL MOUNT CONNECTOR (18) #20 SOCKET CONTACTS W/ SOLDER CUP MAXI-CON-X	
SCALE	SIZE	SHEET	CUSTOMER: STANDARD PRODUCT	
NTS	B	1 OF 1	PART NUMBER: 14282-18SG-3ES	
FILE:	DIRECTORY:	PART	REV	
14282-18SG-3ES	SLW	NUMBER: 14282-18SG-3ES	A	