

- NOTES:**
1. FINISHED PRODUCT TO BE BOXED.  
GASKETS AND HEX NUTS MAY BE BULK PACKAGED SEPARATELY.
  2. CONTACTS ASSEMBLED INTO CONNECTOR.
  3. REAR WELL FILLED WITH BLACK EPOXY.
  4. ALL DIMENSIONS ARE REFERENCE EXCEPT THOSE WITH A TOLERANCE.
  5. SEE DRAWING HPMXSTD FOR HOLE PATTERN

CUSTOMER APPROVAL	
THIS DOCUMENT CONTAINS CONFIDENTIAL INFORMATION PROPRIETARY TO CONXALL CORPORATION. ANY REPRODUCTION, DISCLOSURE, OR USE OF THIS DOCUMENT /INFORMATION IS EXPRESSLY PROHIBITED UNLESS AUTHORIZED IN WRITING BY CONXALL CORPORATION.	
CHECKED BY: _____	APPROVED BY: _____
DATE: _____	

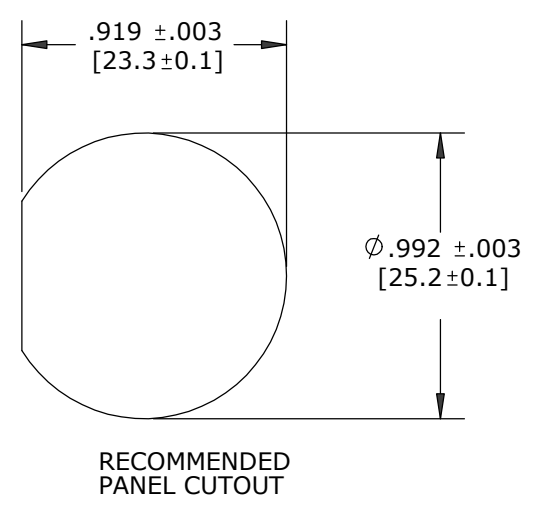
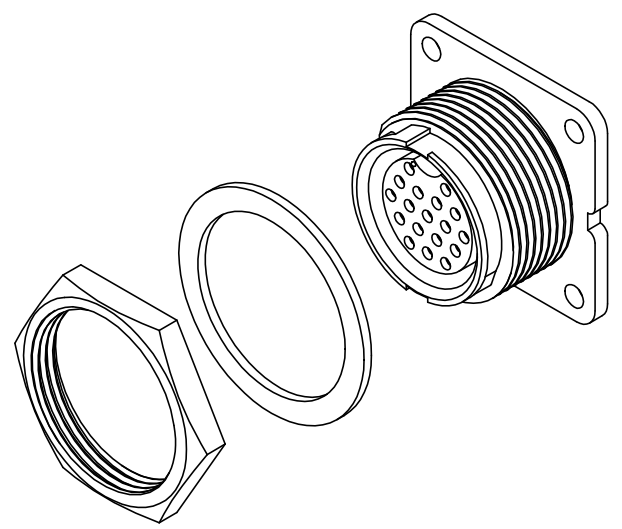
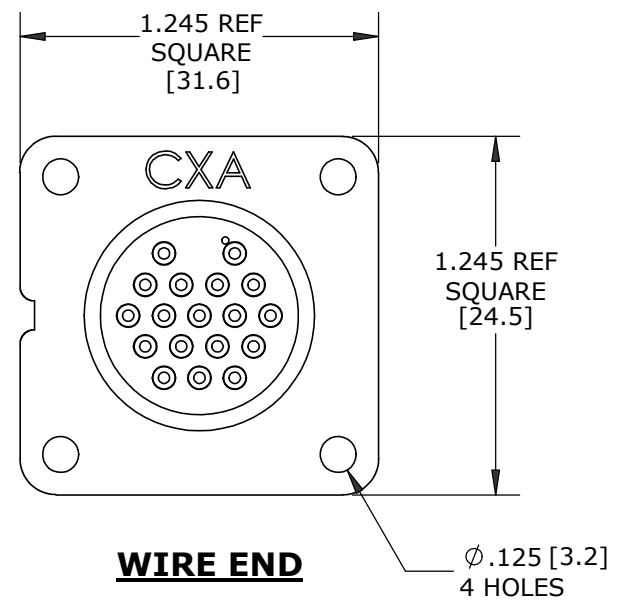
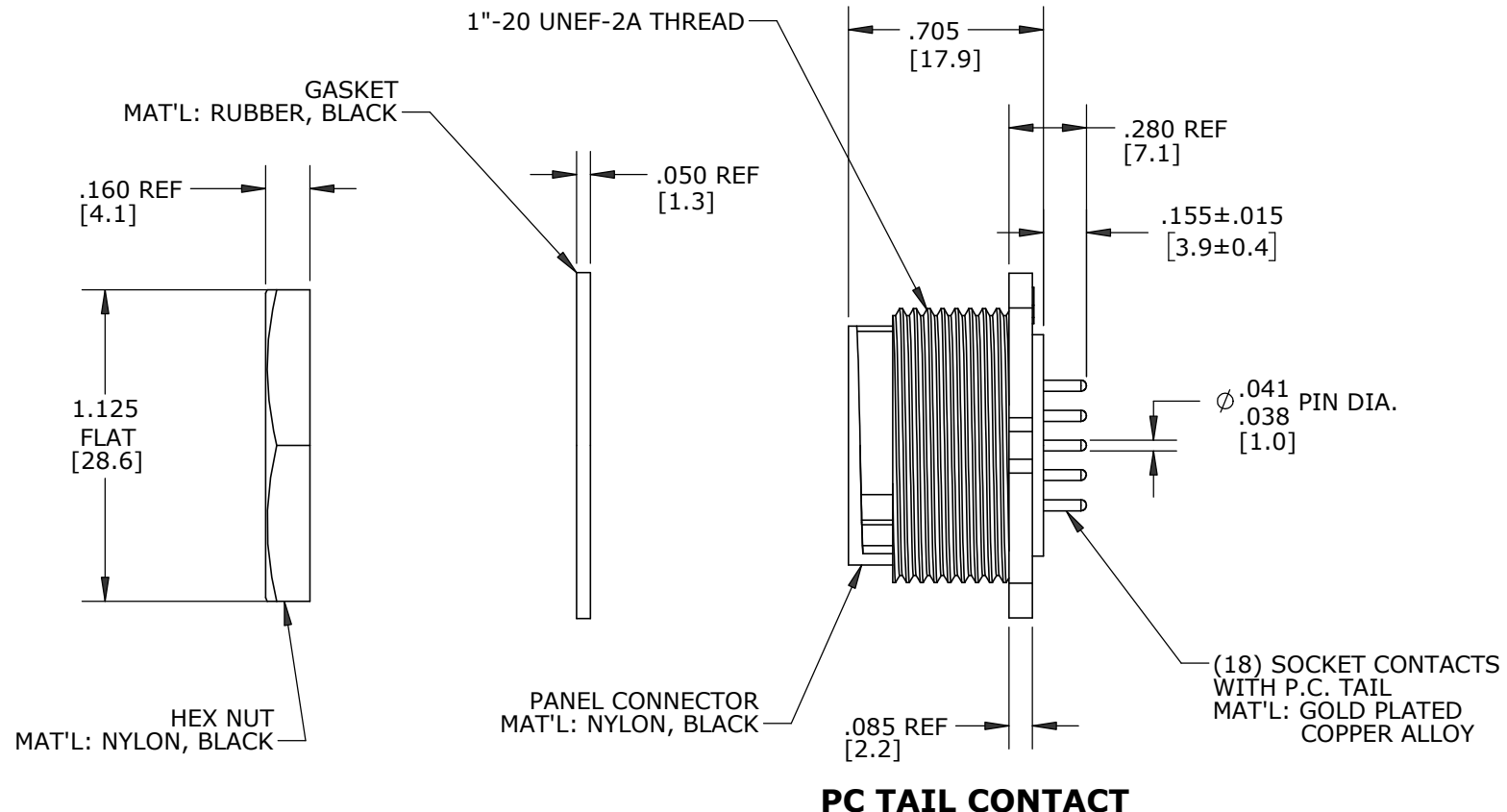
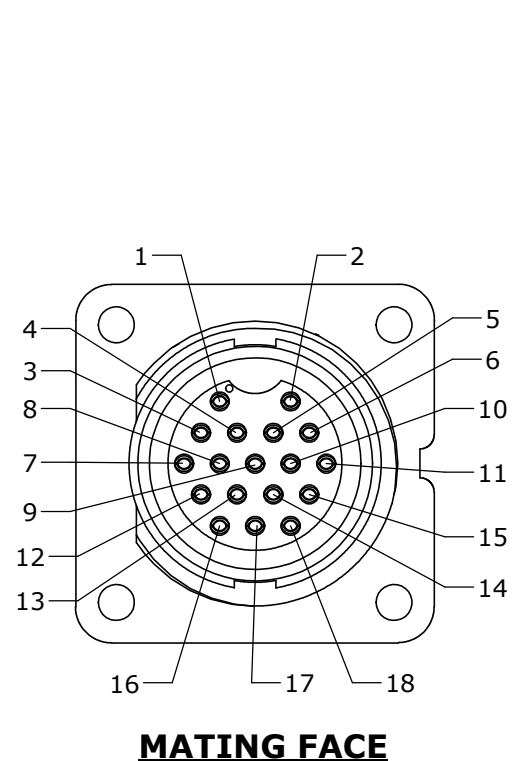

DIMENSIONS IN BRACKETS [ ] ARE METRIC

**RoHS COMPLIANT**

B	SS	06-25-20	CHANGED PACKAGING FROM BAGGED TO BOXED PER ECR 9526
A	MA	10-09-17	DRAWING CREATED PER ECR 9203
REV.	INIT.	DATE	DESCRIPTION
ORIG. DRAWN BY: MA		DATE: 10-09-17	<p>601 E. WILDWOOD VILLA PARK, IL 60181</p>
CHECKED BY:			
APPROVED BY:			TITLE: CONNECTOR ASS'Y KIT 18 POLE, SOCKET MAXI-CON-X
SCALE: NTS	SIZE: B	SHEET: 1 OF 1	CUSTOMER: STANDARD PRODUCT
FILE: 14281-18SG-3ES	DIRECTORY: SLW	PART NUMBER: 14281-18SG-3ES	REV: B