

ASSY P/N	CABLE O.D.
13382-10SG-321	0.21-0.25 [5.3-6.3mm]
13382-10SG-326	0.26-0.30 [6.6-7.6mm]
13382-10SG-331	0.31-0.38 [7.8-9.6mm]

- NOTES:**
1. ALL PARTS TO BE BULK PACKED.
  2. CONTACTS TO BE INSERT INTO CONNECTOR.
  3. SEE DRAWING HPMXSTD FOR HOLE PATTERN

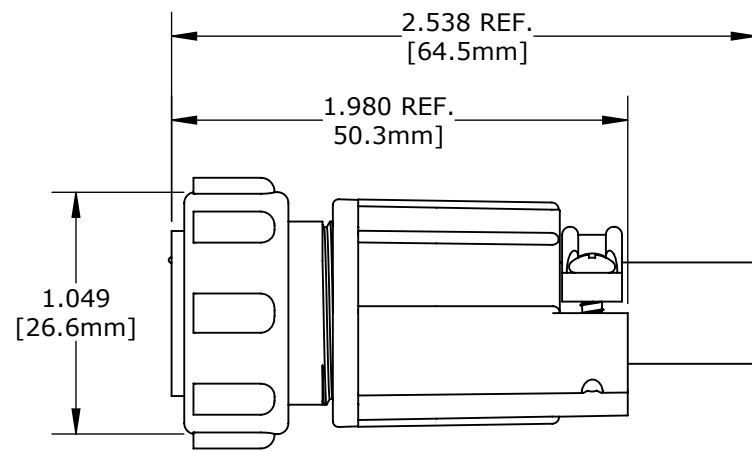
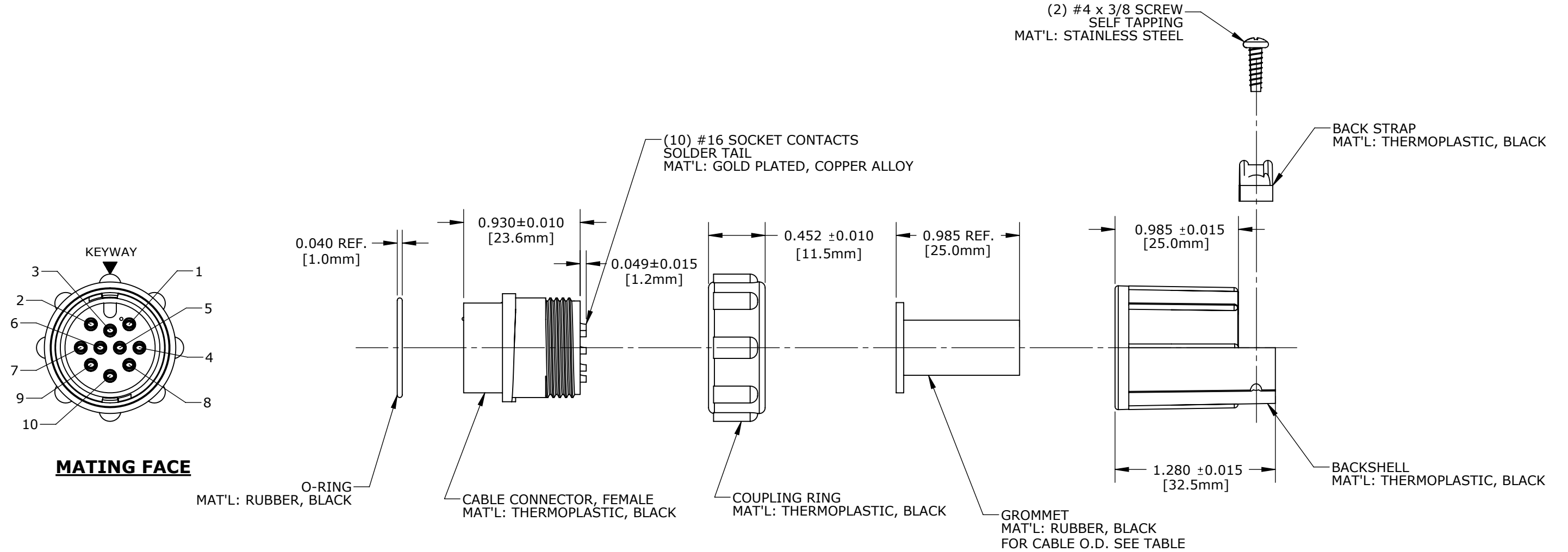

DIMENSIONS IN BRACKETS [ ] ARE METRIC.

**CUSTOMER APPROVAL**

THIS DOCUMENT CONTAINS CONFIDENTIAL INFORMATION PROPRIETARY TO CONXALL CORPORATION. ANY REPRODUCTION, DISCLOSURE, OR USE OF THIS DOCUMENT / INFORMATION IS EXPRESSLY PROHIBITED UNLESS AUTHORIZED IN WRITING BY CONXALL CORPORATION.

CHECKED BY: \_\_\_\_\_

APPROVED BY: \_\_\_\_\_

DATE: \_\_\_\_\_

**RoHS COMPLIANT**

A	AN	10-02-14	DRAWING CREATED PER DOR 14-E149SL #35	
REV.	INIT.	DATE	DESCRIPTION	
	AN	10-02-14	ALL INFORMATION ILLUSTRATED IS THE PROPERTY OF "CONXALL CORPORATION". UNAUTHORIZED DUPLICATION OR DISTRIBUTION OF THIS DOCUMENT IS PROHIBITED.	
ALL UNITS ARE IN FEET, INCHES, FRACTION OF INCHES AND DECIMALS.				
- CRITICAL CHARACTERISTIC FLAG PER SPEC. XXXX			TITLE: CONNECTOR KIT (10) #16 SOCKET CONTACTS, SOLDER MAXI-CON-X CUSTOMER: STANDARD PRODUCT	
SCALE	SIZE	SHEET	PART NUMBER: 13382-10SG-3XX	
NTS	B	1 OF 1	REV A	
FILE:	DIRECTORY:			
13382-10SG-3XX	SLW			

CUSTOMER PRINT

PART NUMBER: 13382-10SG-3XX